

# Installation Note

---

## Agilent PSA Series Spectrum Analyzers Switchable Microwave Preselector Bypass Option 123



**Agilent Technologies**

Part Number E4440-90324 Supersedes: E4440-90309  
Printed in USA July 2006



E4440- 90324

**Notice.**

The information contained in this document is subject to change without notice.

Agilent Technologies makes no warranty of any kind with regard to this material, including but not limited to, the implied warranties of merchantability and fitness for a particular purpose. Agilent Technologies shall not be liable for errors contained herein or for incidental or consequential damages in connection with the furnishing, performance, or use of this material.

## Switchable Microwave Preselector Bypass Installation Kit

Products Affected:	PSA E4446A PSA E4447A PSA E4448A
Serial Numbers:	US4430 / US9999 MY4430 / MY9999 SG4430 / SG9999
To Be Performed By:	<input checked="" type="checkbox"/> Agilent Service Center <input checked="" type="checkbox"/> Personnel Qualified by Agilent <input type="checkbox"/> Customer
Estimated Installation Time:	2.5 Hours
Estimated Adjustment and Verification Time:	5.5 Hours (see note 1)
Additional Recommended Task	Agilent recommends that a full calibration be performed to verify instrument specifications. (see note 2)

### Introduction

This installation note explains how to install the Switchable Microwave Preselector Bypass into newer instruments that have the serial prefix listed above.

Because the mixer in this kit requires the same FELOMA LO output that the external mixing option AYZ requires, the two options cannot be installed at the same time.

The retrofit adds a switchable alternate signal path when the analyzer start frequency is above 3.05 GHz. This alternate path bypasses the preselector filter and mixer in the normal highband path. The advantage of bypassing the preselector is that the preselector filter will drift with time and temperature and will cause small amplitude errors.

When the preselector is bypassed, images, multiples and out of band responses will appear on the analyzer display since there is no longer a bandpass filter present to limit the input frequency range of the analyzer. Therefore, the display may show many signal responses even though only one response is the true signal. Since the preselector can be switched in or out easily, it is possible to find a signal in preselected mode and tune to it, then switch the preselector out and measure it.

**NOTE**

1. The installation of this kit requires that some re-adjustment and performance testing be performed in order to assure the new option is functioning properly. This installation note includes a list of required adjustments and performance tests. Completing the list of required performance tests does not guarantee the instrument meets all specifications.
  2. The instrument end user must determine whether they need a full instrument calibration following the installation of the kit. If full calibration is required, arrangements regarding the level of calibration must be made between the end user and the calibration provider.
  3. This option is licensed for one instrument model number/serial number combination. The license key will only install on the designated instrument.
-

**Contents**

<b>Quantity</b>	<b>Description</b>	<b>Agilent Part Number</b>
1	Installation Note	This note
1	Option Upgrade Entitlement Certificate	5964-5141
1	User's Guide, Volume 1	---
1	Specifications Guide	---
1	3 dB Attenuator	0955-0246
1	Preselector Bypass Mixer	1NB7-8539
1	Mixer Bias Board	E4440-60254
1	Option Driver Assembly	E4440-60253
1	SW 3, Switch coax	N1810-60052
1	SW 5, Switch 50 GHz	87222-60015
1	Bracket, mixer	E4440-00062
1	Bracket, coax Switch	E4440-00076
1	Bracket, switch	E4440-00063
1	W89, Cable, coax, Switch SW3 bottom port to RHYTHM/SBTX	E4440-60373
1	W90, Cable, flat flex, Preselector Bypass Mixer to Mixer Bias Board	8150-5698
1	W92, Cable, Ribbon, Option Driver Assembly J8 to SW5	E4440-60455
1	W93, Cable, coax, Preselector Bypass Mixer to Switch 3 Coax Switch top port	E4440-60298
1	W94, Cable, coax, Coax Switch SW3 center connector to 3RD Converter	E4440-60373
1	W95, Cable, ribbon, Option Driver Assembly J7 to Mixer Bias Board (opt 123)	E4440-60397
1	W96, Cable, ribbon, Driver board J9 to Coax switch	E4440-60427
1	W98, Cable, semi-rigid, Preselector Bypass Mixer LO IN to W46 / 3 dB attenuator	E4446-20074
1	W99, Cable, semi-rigid, Preselector Bypass Mixer to Switch SW5 Port 4	E4446-20318
1	W100, Cable, semi-rigid, Switch SW5 port 1 from attenuator. (For instruments that do not have opt 110)	E4446-20071

## Switchable Microwave Preselector Bypass Installation Kit

Quantity	Description	Agilent Part Number
1	W101, Cable, semi-rigid, Switch SW4 port 4 to Switch SW5 port 1 (For instruments that have Opt 110)	E4446-20081
1	W105, Cable, semi-rigid, Switch SW5 port 2 to W34 cable that goes to A10 RYTHM/SBTX	E4446-20080
1	W46, Cable semi-rigid, A12 FELOMA to W98 / 3 dB attenuator	E4440-20035
1	Thermal Pad	N1996-40018
12	Screw, M3 X 0.5 8 MM-LG	0515-0372
2	Screw, M3 X 0.5 18 MM-LG	0515-0666
2	Screw, M3.5 X 0.6 8 MM-LG	0515-0458
3	Screw, M2.5 X 0.45, 6 MM-LG	0515-1934
2	Screw, M3 X 0.5, 6 MM-LG	0515-0430
1	Clamp, cable, PVC	1400-0611
2	SMA Hole Plug	6960-0076

### Tools Required

- T-8 Torx driver
- T-10 Torx driver
- T-20 Torx driver
- 9/16-inch open end wrench
- 9/16-inch nut driver
- tweezers
- 1/4-inch deep socket driver (for instruments with Option AYZ)
- Calibration software. Latest software information and downloads available at <http://www.agilent.com/find/calibrationsoftware>
- Test equipment supported by the calibration software.
- PSA Series Spectrum Analyzer and Service Guide. This manual is available as part of the E4446AU, E4447AU, or E4448AU Option OBW kits.
- Microsoft Windows based personnel computer with LAN card and CD-ROM drive
- Windows 2000, Windows XP
- Crossover cable if PC or analyzer is not connected to network. Use a CAT, RJ45 cable with cross pinning, Agilent p/n 8121-0545
- Firmware A.0 9.10 or later. Download the latest revision form [http://www.agilent.com/find/psa\\_firmware](http://www.agilent.com/find/psa_firmware), or order the Firmware Update kit.

Depending on your model number, the firmware update kit is ordered as: Order E444xAU (Qty.1) Option UE2 (Qty. 1), where the “x” is the last digit of the model number. For example: E4440AU option UE2.

## Installation Procedure

For assistance at any time during this procedure, get in touch with your nearest Agilent Technologies Sales and Service Office. To find your local Agilent office access the following URL:

<http://www.agilent.com/find/assist>

### Preliminary Hardware Verification

1. Check for the presence of Option 110, Preamplifier by pressing **System, More, Show System**, and look at the option list.
  - If Option 110 is present follow the instructions in this installation note in the section named “Installing Option 123 with Option 110”.
  - If Option 110 is not present then follow the instructions in this installation note in the section named “Installing Option 123 without Option 110”.
2. Check for the presence of Option AYZ, External Mixing, by pressing **System, More, Show System**, and look at the option list.
  - If Option AYZ is present it must be uninstalled before Option 123 can be installed.
    - a. Delete Option AYZ License by pressing **System, More, More, Licensing, Option**. Use the front panel numerical key pad to enter the option designator AYZ and press the **Enter** key. Press **Delete Option**.
    - b. Check that Option AYZ has been removed by pressing **System, More, Show System**, and looking at the option list.
    - c. Follow the instructions in this installation note in the section named “Uninstalling Option AYZ” to remove the Option AYZ hardware.
  - If Option AYZ is not present, then skip the section named “Uninstalling Option AYZ”.

### Before you begin the kit installation:

The instrument should be fully functional and pass all of the power on align tests. If an alignment test fails, either note the failure and go on with the kit installation or repair the problem now. Since the following installation involves removing and replacing cables and removing and reinstalling major assemblies, you must be aware of the instrument status before you begin the kit installation.



## Remove the Outer Case

---

**CAUTION** If the instrument is placed on its face during any of the following procedures, be sure to use a soft surface or soft cloth to avoid damage to the front panel, keys, or input connector.

---

1. Disconnect the instrument from ac power.
2. Refer to Figure 1. Remove the two handles on the sides of the instrument as shown. Use the T-20 driver to loosen the screws that attach each handle (1). Remove the handles.
3. Remove the four bottom feet (2). Lift up on the tabs on the feet, and slide the feet in the direction indicated by the arrows.
4. Remove the four screws (3) that hold the rear feet (4) in place.
5. Pull the instrument cover (5) off toward the rear of the instrument.

**Figure 1 Instrument Outer Case Removal**

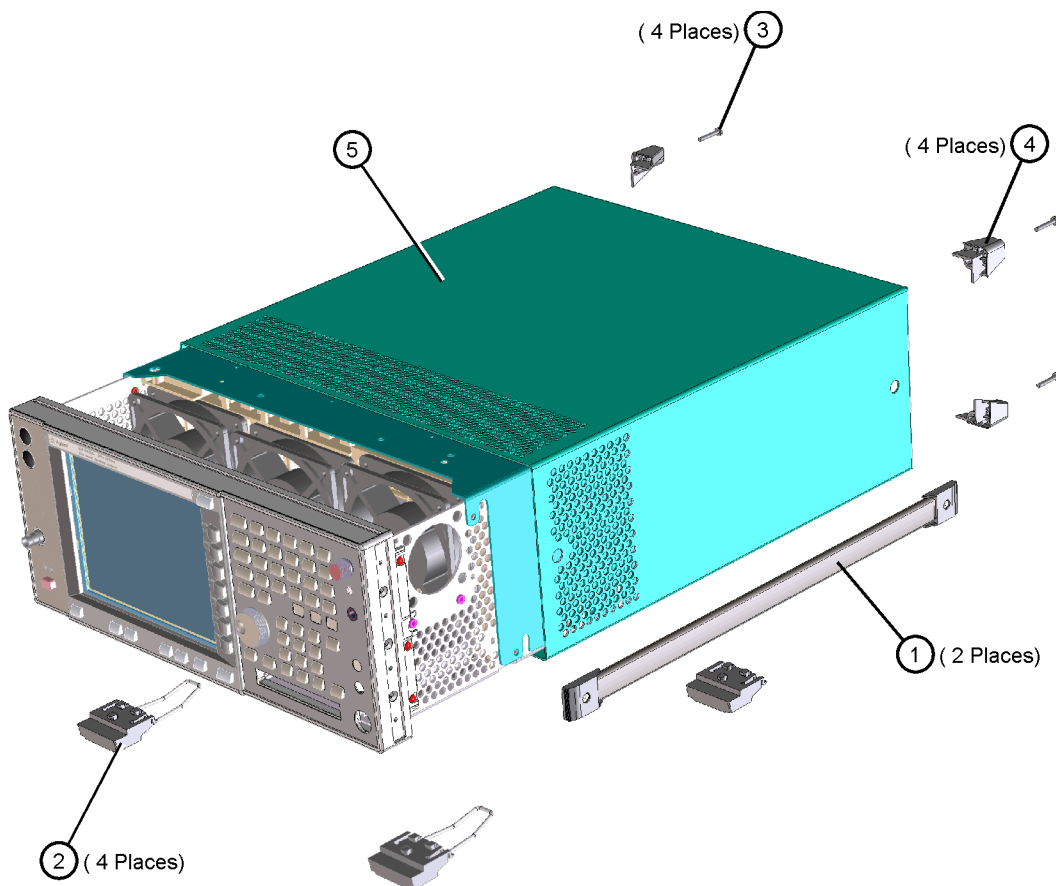

de83a

## Remove the Top Brace

1. Refer to Figure 2. Use the T-10 driver to remove the top screws (3) (one screw is under the security label), and the side screws (2) attaching the top brace (1) to the deck.
2. Remove the top brace from the deck.

**Figure 2**      **Top Brace Removal**

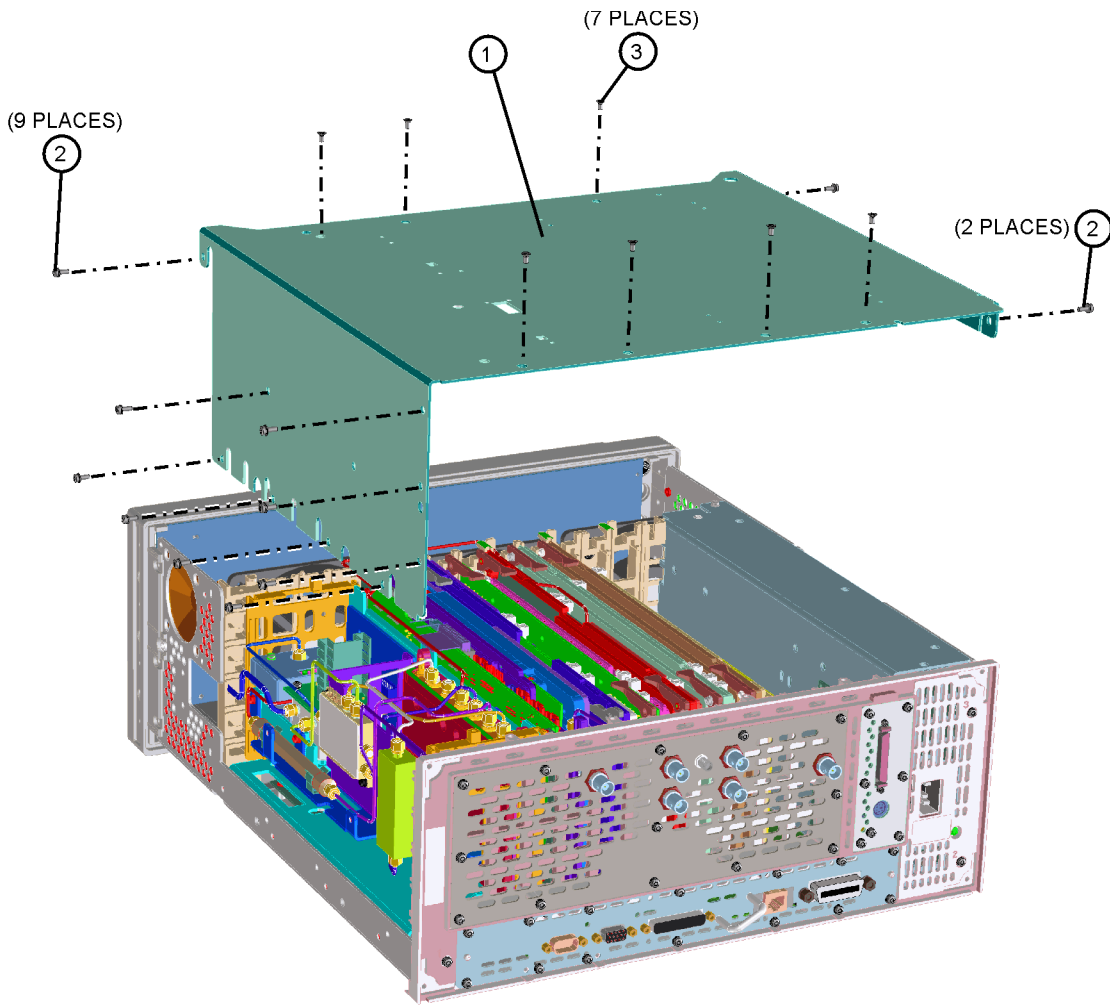

## Uninstalling Option AYZ

1. Refer to Figure 3. Locate and disconnect semi-rigid cable W45 from W46. Remove W46 from the FELOMA and discard W46 since it is no longer needed.

**Figure 3** W46 Cable Location

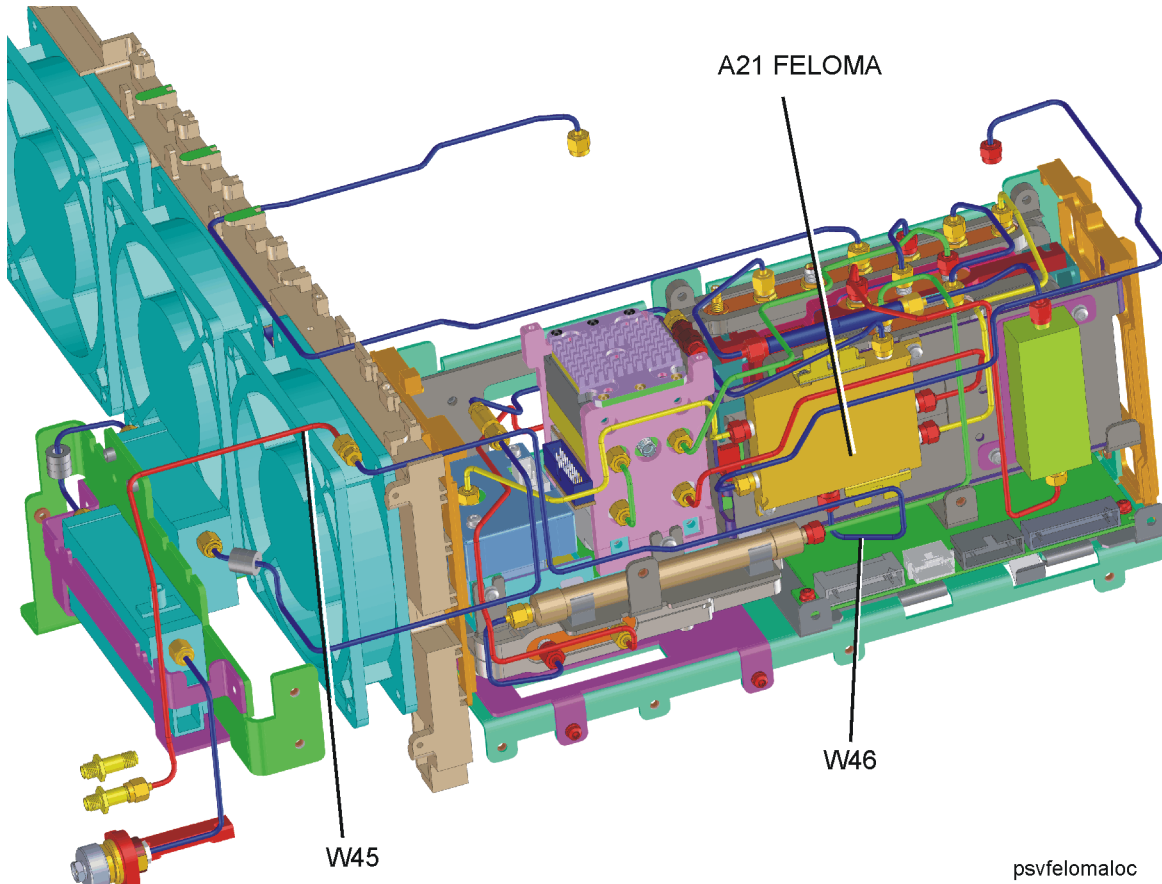

2. Remove the front frame as described in the instructions in this installation note under the section called “Drop the Front Frame”.
3. Refer to Figure 4. Remove cable W45 from the front panel 1st LO Out. Discard this cable.

**Figure 4** W45 Cable Location at Front Panel

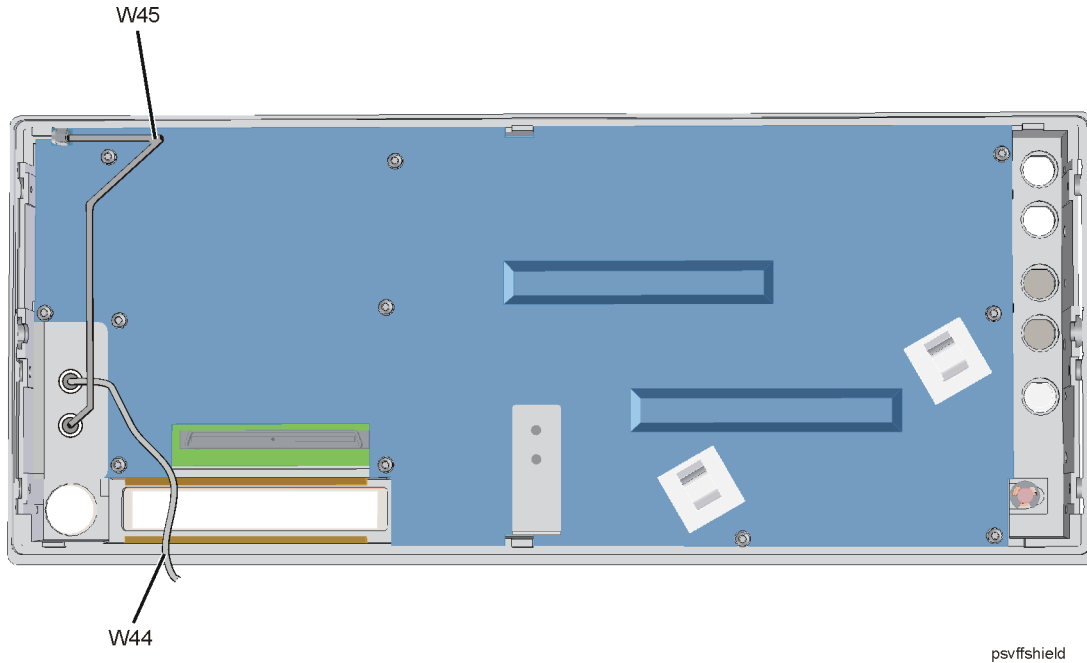

4. Locate and remove cable W44 (IF Input on the front panel to J3 on the 3rd Converter Assembly). Discard this cable.
5. Locate the two SMA Hole Plugs (6960-0076) from the kit.
6. Remove the 1st LO Out and IF Input Front Panel SMA Connectors with a ¼ inch deep socket. Ensure you do not scratch the front panel. Discard the SMA connectors and replace them with the SMA Hole Plugs.

## Drop the Front Frame

1. Refer to Figure 5. Using the T-10 driver, remove the 7 screws (1) that attach the front frame assembly (2) to the deck.
2. Pull the front frame off of the deck until it is disengaged from the disc drive.
3. At this point, the front frame can be placed flat on the bench for service while still attached to the instrument.

**Figure 5**      **Front Frame Assembly Removal**

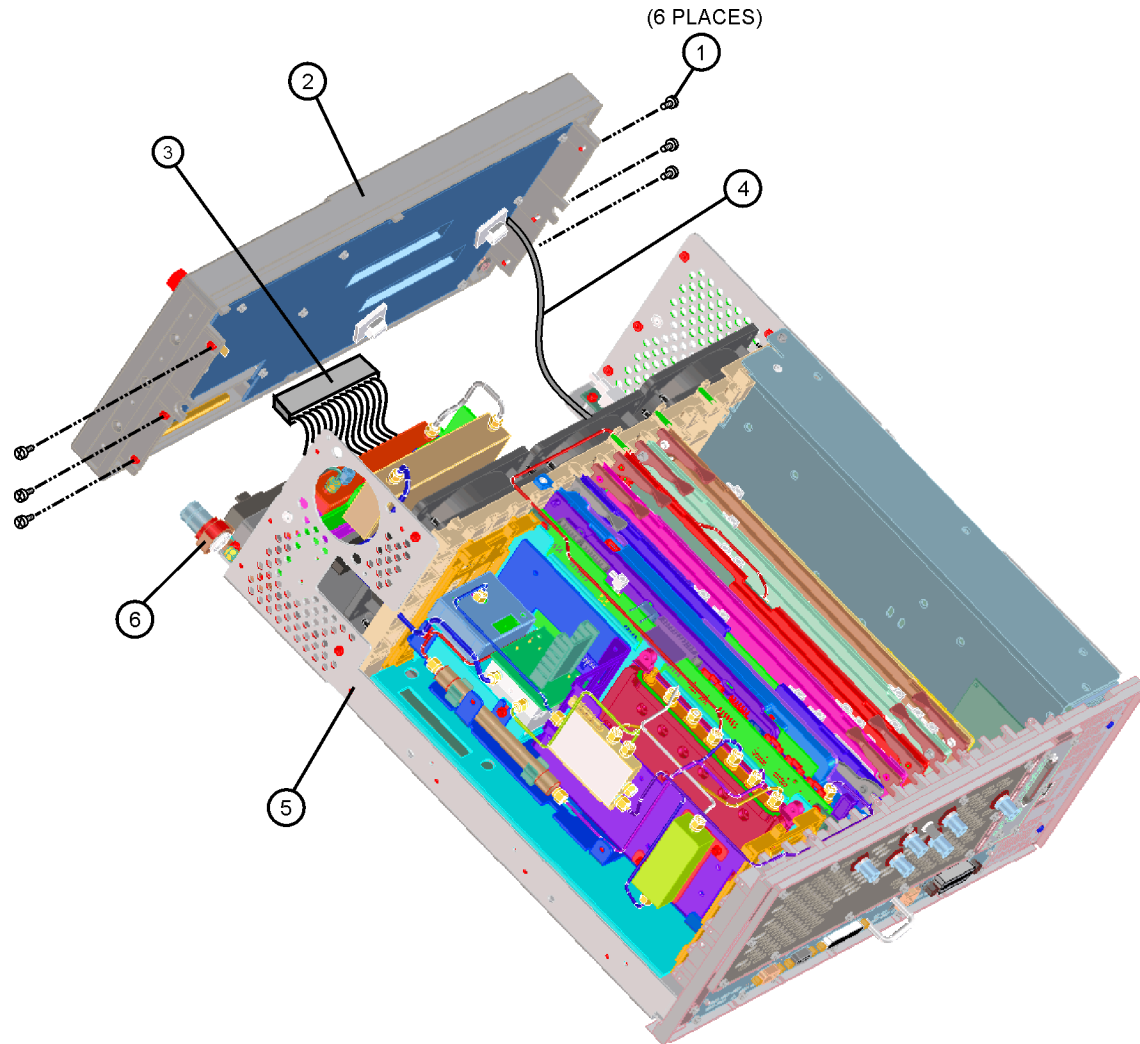

se86a

## Installing Option 123 with Option 110

1. Locate the Coaxial Switch SW3 (N1810-60052) from the kit.
2. Locate the E4446-60373 gray flexible cable from the kit. This cable is reference designator W94. Connect cable W94 to Coaxial Switch SW3 Port C. Torque to 10 in-lbs.
3. Locate the E4446-60289 gray flexible cable from the kit. This cable is reference designator W93. Connect cable W93 to Coaxial Switch SW3 Port 2. Torque to 10 in-lbs.
4. Locate the E4446-60373 gray flexible cable from the kit. This cable is reference designator W89. Connect cable W89 to Coaxial Switch SW3 Port 1. Torque to 10 in-lbs.
5. Locate the Coaxial Switch Bracket (E4440-00076) from the kit. Refer to Figure 6. Install Coaxial Switch SW3 to the Bracket with two screws (0515-0375). Torque to 9 in-lbs.

**Figure 6** SW3 and Bracket

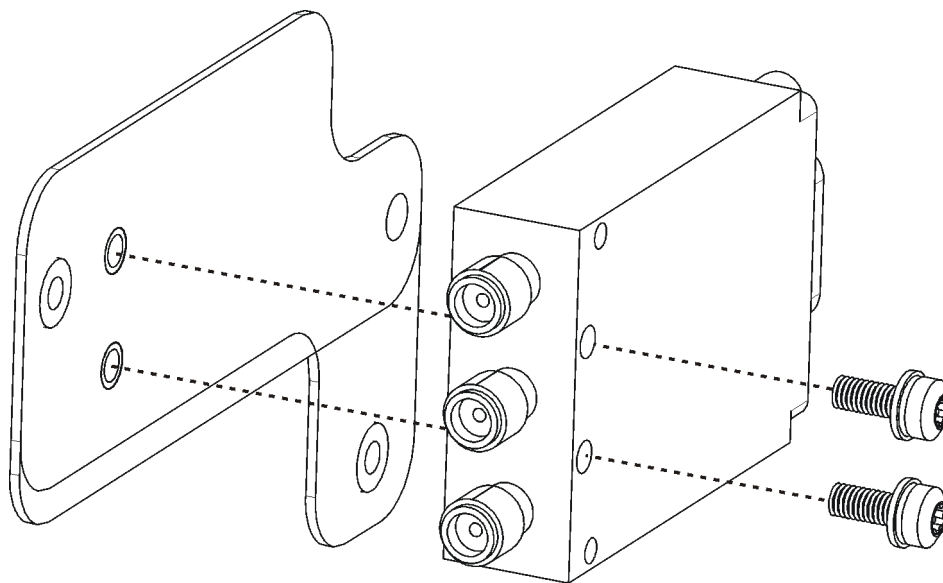

sw3\_bracket

6. Locate the E4446-60427 Ribbon Cable from the kit. This cable is reference designator W96. Connect cable W96 to Coaxial Switch SW3.
7. Refer to Figure 7. Install the Coaxial Switch Assembly (1) to the chassis with two screws (0515-0430) (2) as shown. Torque to 9 in-lbs.

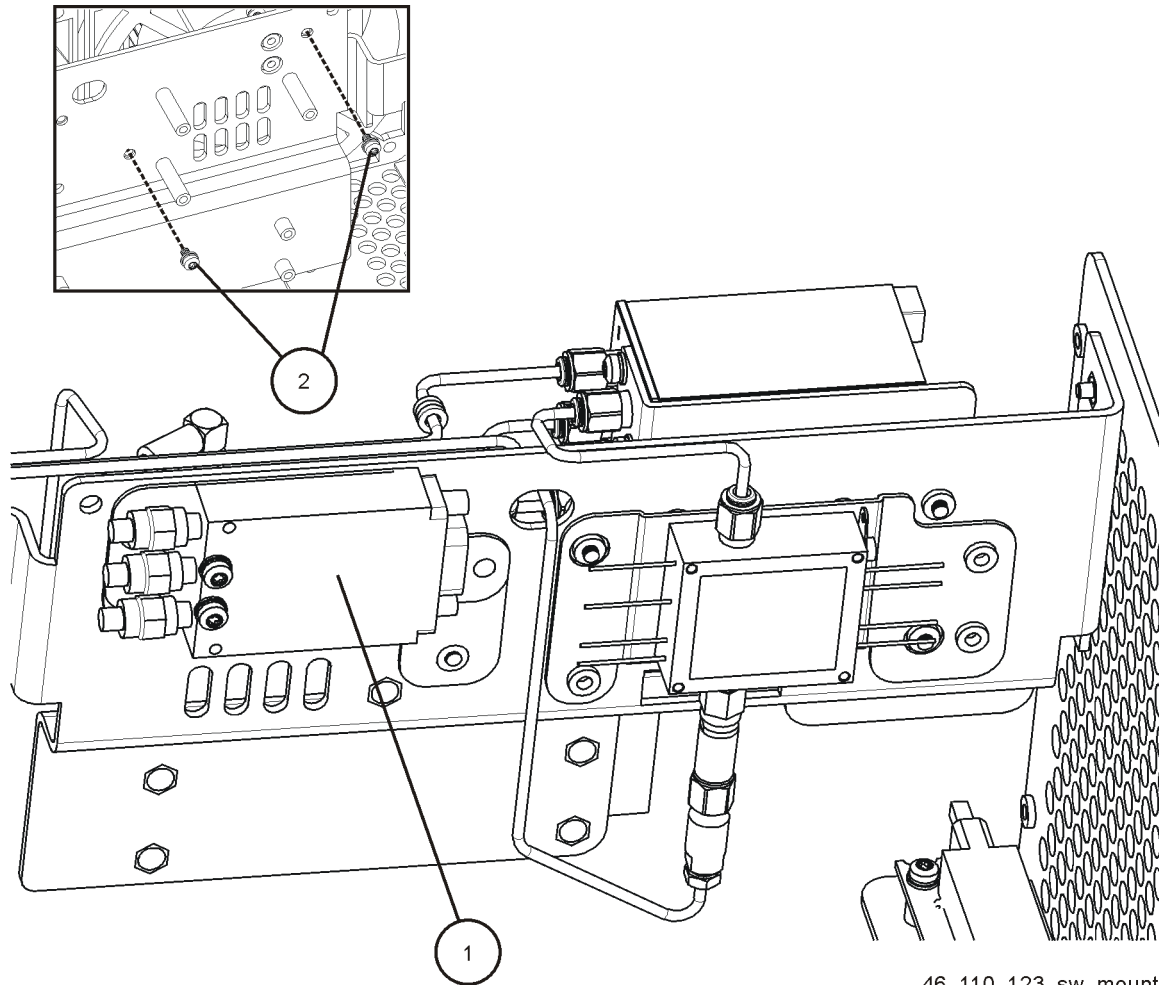
**Figure 7 Coaxial Switch Assembly Installation**

46\_110\_123\_sw\_mount

8. Refer to Figure 8. Remove the screw from the cable hold down rod on the mid web to allow the “10” cable and other cables to be free.
9. In order to remove the RYTHM end of the cable, and replace the cable, several board assemblies must be removed. Refer to Figure 8 and Figure 9. Please note the position and routing of all cables. All of the flexible coax cables are color coded, but the ribbon cables are not.

**Figure 8 Assembly and Cable Location**

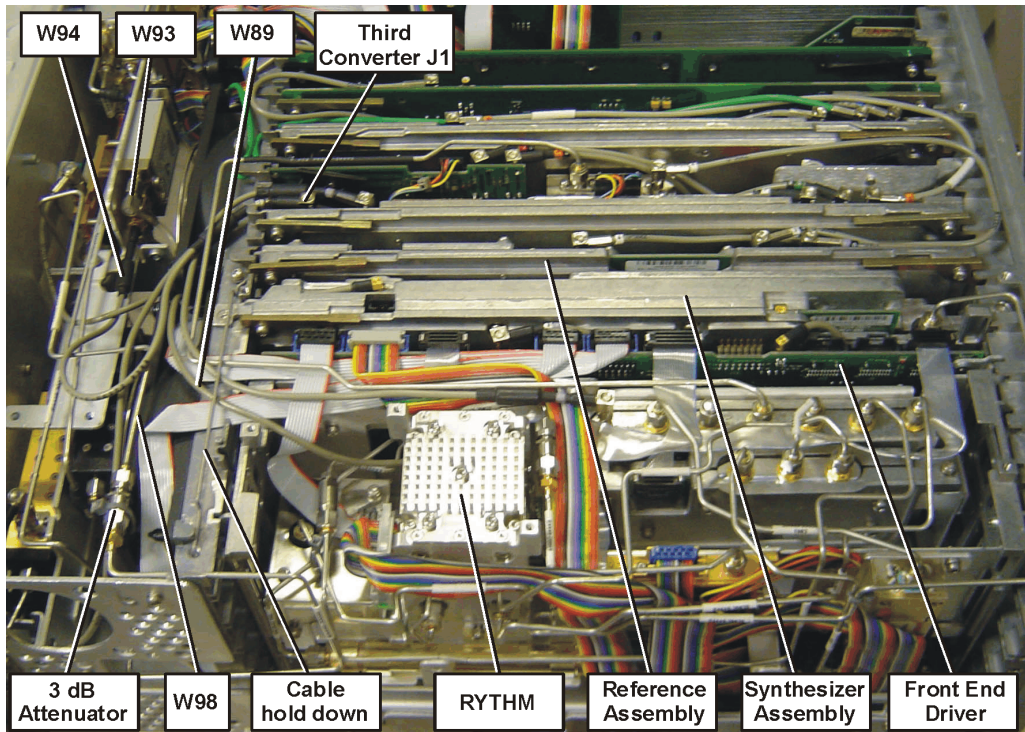

**Figure 9 Options 110 and 123 Rear View**

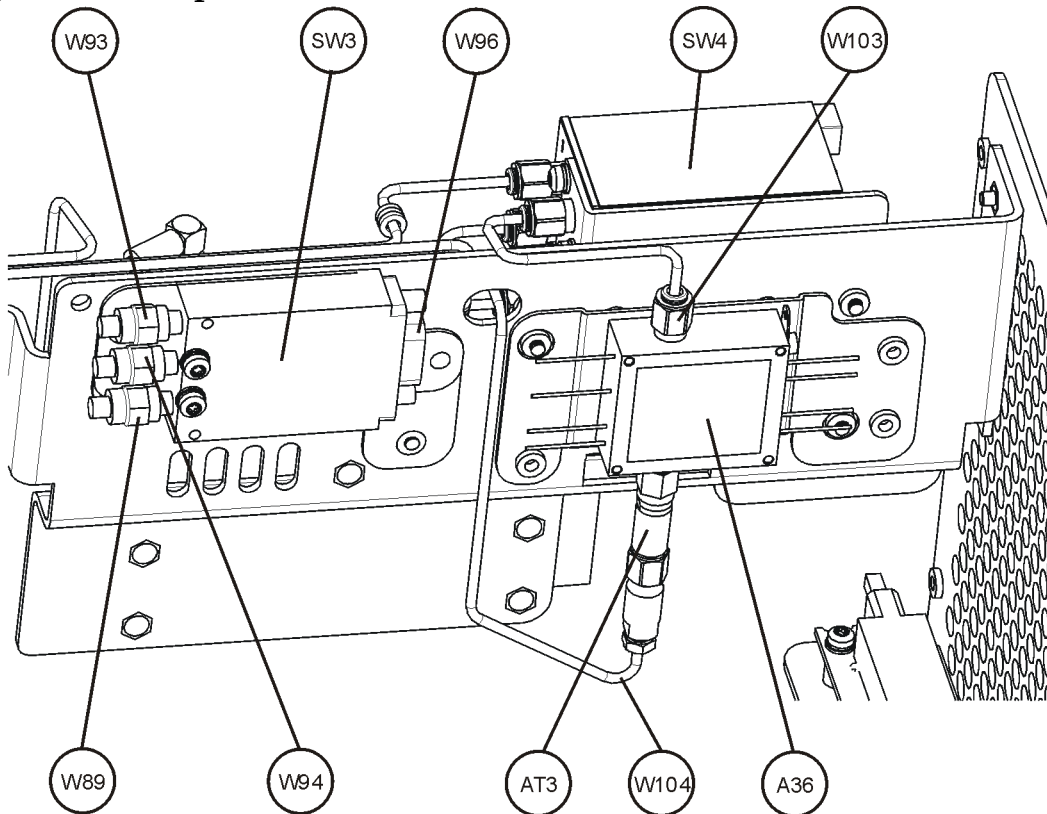

46 110 123 rear



10. Remove the Front End Driver being careful to avoid damaging the ribbon cables.
11. Remove the Synthesizer assembly after removing the rigid cable and the two retaining screws.
12. Remove the Reference assembly.
13. Locate cable W17, (RYTHM highband output to 3rd Converter J1) and take note of the cable routing. Refer to Figure 10. Using needle nose pliers, carefully grab the body of the cable SMB connector and gently rock the SMB connector free of the RYTHM. Discard this cable.

**Figure 10**      **W17 Location**

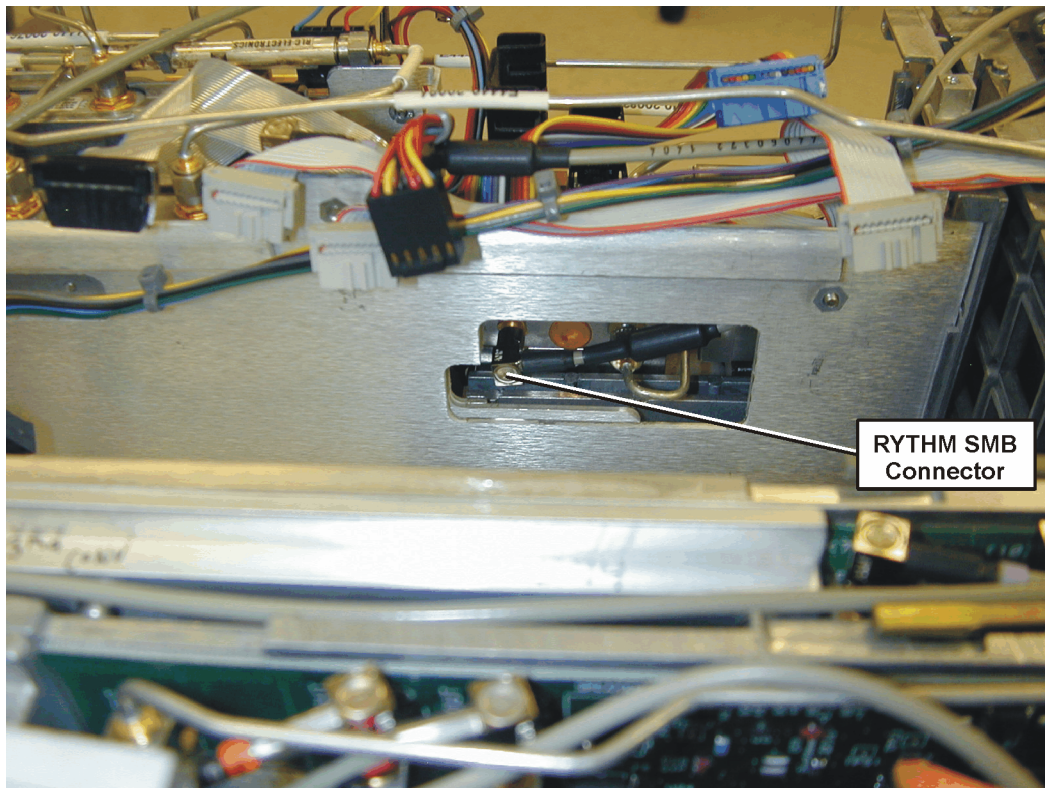

## Installation Procedure

14. Locate cable W89, one end is already connected to Switch SW3 bottom port. Refer to Figure 11. Route the cable next to the RF section sheet metal and directly to the RYTHM as shown. Carefully align the SMB connector end of the cable with the RYTHM connector by looking through the hole in the chassis. Press the SMB connector on.

**Figure 11 W89 Location**

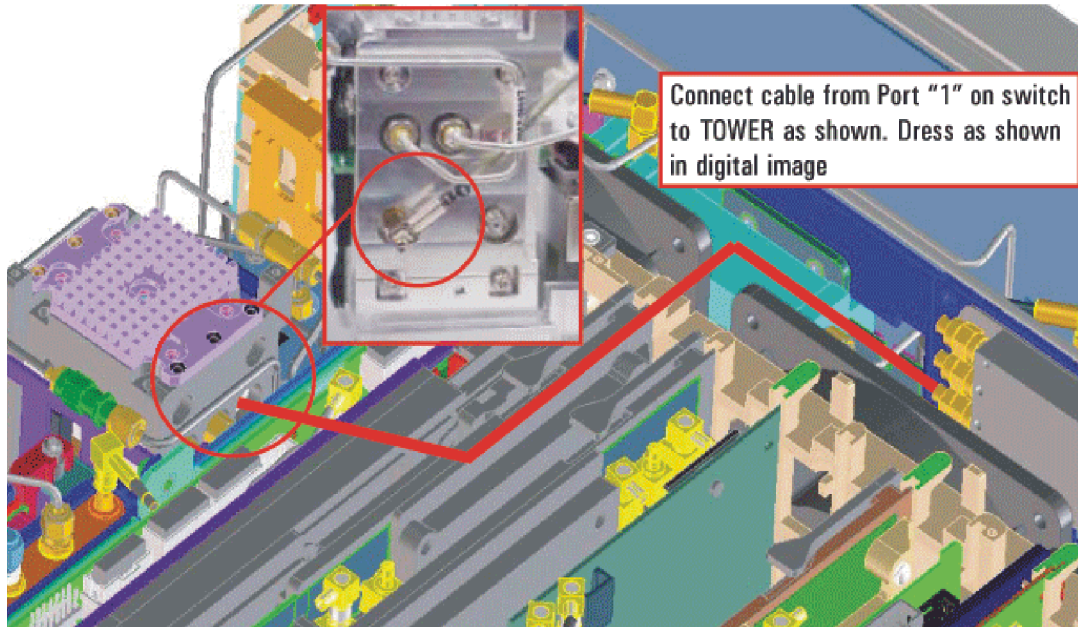

15. Reinstall the A13 Front End Driver, Synthesizer Assembly and the Reference Assembly. Assure all cables are routed correctly.

---

**NOTE** The shrink-wrapped ferrite beads on the cable can be moved slightly to aid cable routing.

---

16. Refer to Figure 12. Locate and remove cable W107 (Switch SW4 Port 4 to W34 on the RYTHM/SBTX). Discard this cable, since it will be replaced by another cable.

**Figure 12 Option 110 Cable Location**

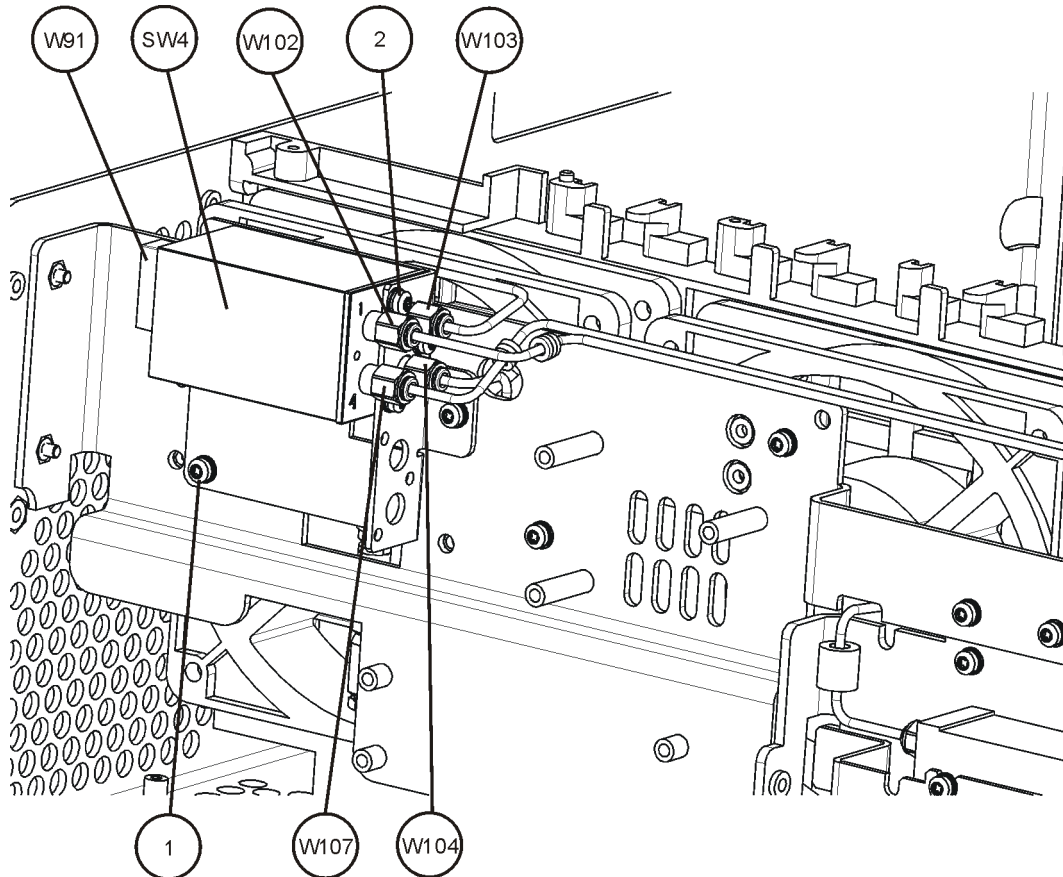

46\_110\_only

17. Locate and remove cable W102 (Switch SW4 Port 3 to Preamplifier). This cable will be replaced later. It is removed to allow the Switch Assembly to be removed.
18. Locate and remove cable W103 (A15 Attenuator to Switch SW4 Port 1). This cable will be replaced later. It is removed to allow the Switch Assembly to be removed.
19. Locate and remove cable W104 (Preamplifier Output to Switch SW4 Port 3). This cable will be replaced later. It is removed to allow the Switch Assembly to be removed.
20. Locate and remove ribbon cable W91 (Option Driver Assembly to Switch SW4). This cable will be replaced later. It is removed to allow the Switch Assembly to be removed.
21. Remove the three screws (2) that attach the Switch Bracket to the Mixer Bracket. Lift the Switch Bracket Assembly from the instrument.
22. Locate Switch SW5 (87222-60015) from the kit. Install Switch SW5 to the Bracket below Switch SW4 with three screws (0515-1934) Torque to 6 in-lbs with a Torx T-8 driver.
23. Re-Install Switch Assembly to Mixer Bracket with three screws (0515-0372) Leave screws loose to allow cables to be installed.

## Installation Procedure

24. Locate Preselector Bypass Mixer (1NB7-8539) and E4440-20318 semi-rigid cable from the kit. This cable is reference designator W99. Refer to Figure 13. Connect W99 to the Preselector Bypass Mixer (1). Leave loose.

**Figure 13 Preselector Bypass Switch and W99 Installation**

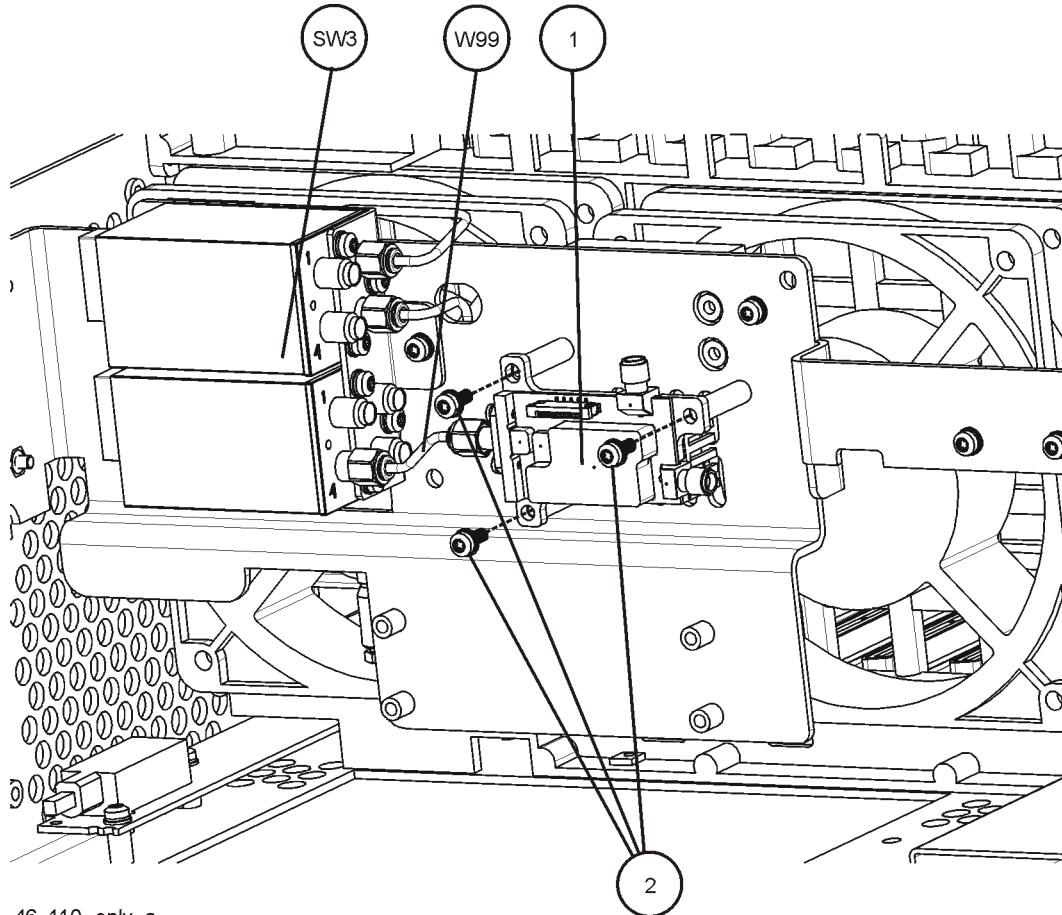

25. Connect cable W99 to Switch SW5 port 4 as shown. Leave loose.
26. Install Preselector Bypass Mixer to the chassis with three screws (2) (0515-0372). Torque to 9 in-lbs.
27. Go back and torque both ends of Cable W99 to 10 in-lbs.
28. Go back and torque the three screws on the Switch Assembly to 9 in-lbs as shown.
29. Locate E4440-60455, Ribbon Cable. This cable is reference designator W92. Connect Ribbon Cable to Switch SW5.
30. Reconnect ribbon cable W91 (Option Driver Assembly J3 to Switch SW4).
31. Locate and remove cable W33 (Attenuator B to W34 on the RYTHM/SBTX). Discard this cable, since it will be replaced by another cable. Leave W34 on the RYTHM/SBTX in place. Refer to Figure 14.

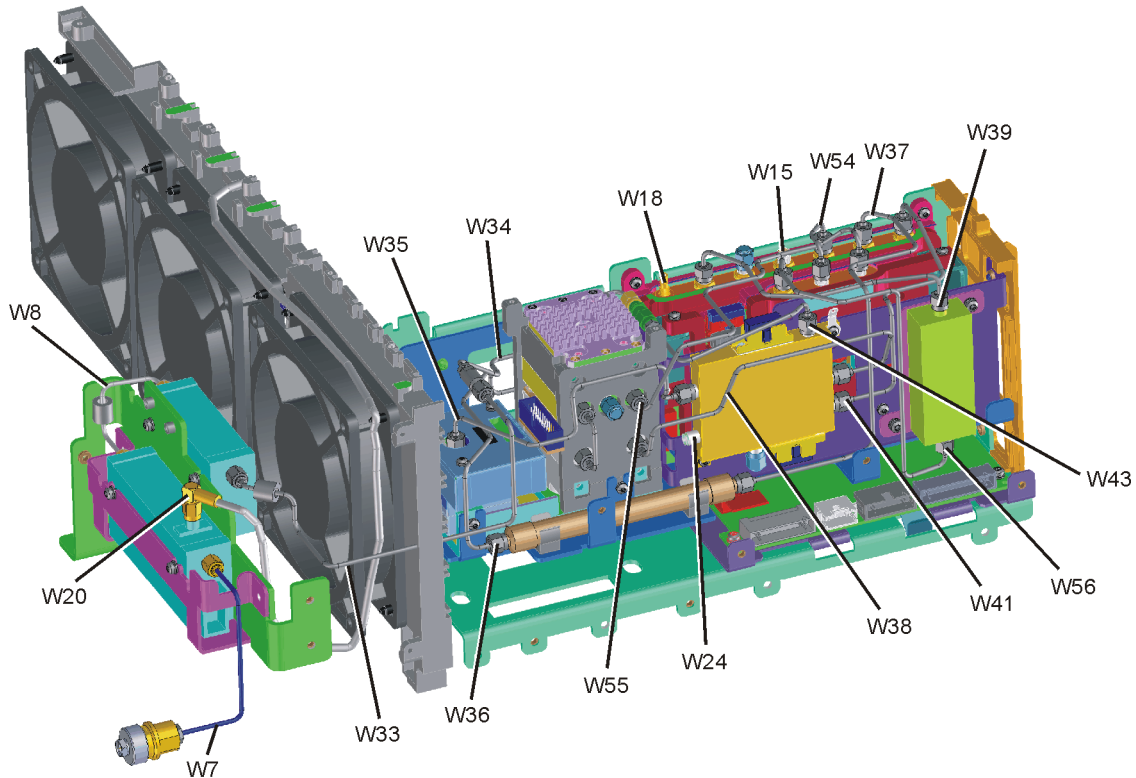
**Figure 14 RF Section Cable Locations**

sn517a

32.If present, locate and remove 50 ohm load from FELOMA J6 LO Out.\*

33.Locate E4446-20035 semi-rigid cable from the kit. This cable is reference designator W46. Connect cable W46 to A12 FELOMA J6 LO Out. Torque to 10 in-lbs.\*

\*Load will already be removed and Cable W46 will already be present if Option AYZ was previously installed.

**CAUTION**

In the following step use a 7 mm wrench on the end of W46 to avoid stressing this cable. The cable can be damaged if it is allowed to rotate when loosening or tightening the Attenuator connector.

34.Locate 0955-0246 3 dB Attenuator from the kit. Connect 3 dB Attenuator to W46 as shown in Figure 8. Torque to 10 in-lbs.

**CAUTION**

In the following step, use a 5/16 inch wrench on the wrench flat at the end of the attenuator to prevent the attenuator body from rotating when installing Cable W98. This attenuator and cable can be damaged if the attenuator is allowed to rotate when loosening or tightening the cable connector.

35.Locate E4446-20074 semi-rigid cable from the kit. (Preselector Bypass Mixer to 3 dB

## Installation Procedure

Attenuator / Cable W46 / A12 FELOMA) This cable is reference designator W98.  
Connect one end of W98 to the 3 dB Attenuator and the other end to the Preselector Bypass Mixer. Refer to Figure 15 and Figure 8. Torque to 10 in-lbs.

36. Connect Cable W94 (Coaxial Switch SW3 Port C to 3rd Converter Assembly J1).

37. Refer to Figure 14 and Figure 15. Locate and install E4446-20080 semi-rigid cable from the kit. This cable is reference designator W105 (Switch SW5 Port 2 to W34 on the RYTHM/SBTX). Torque to 10 in-lbs.

**Figure 15 Options 110 and 123  
E4446A, E4447A, E4448A**

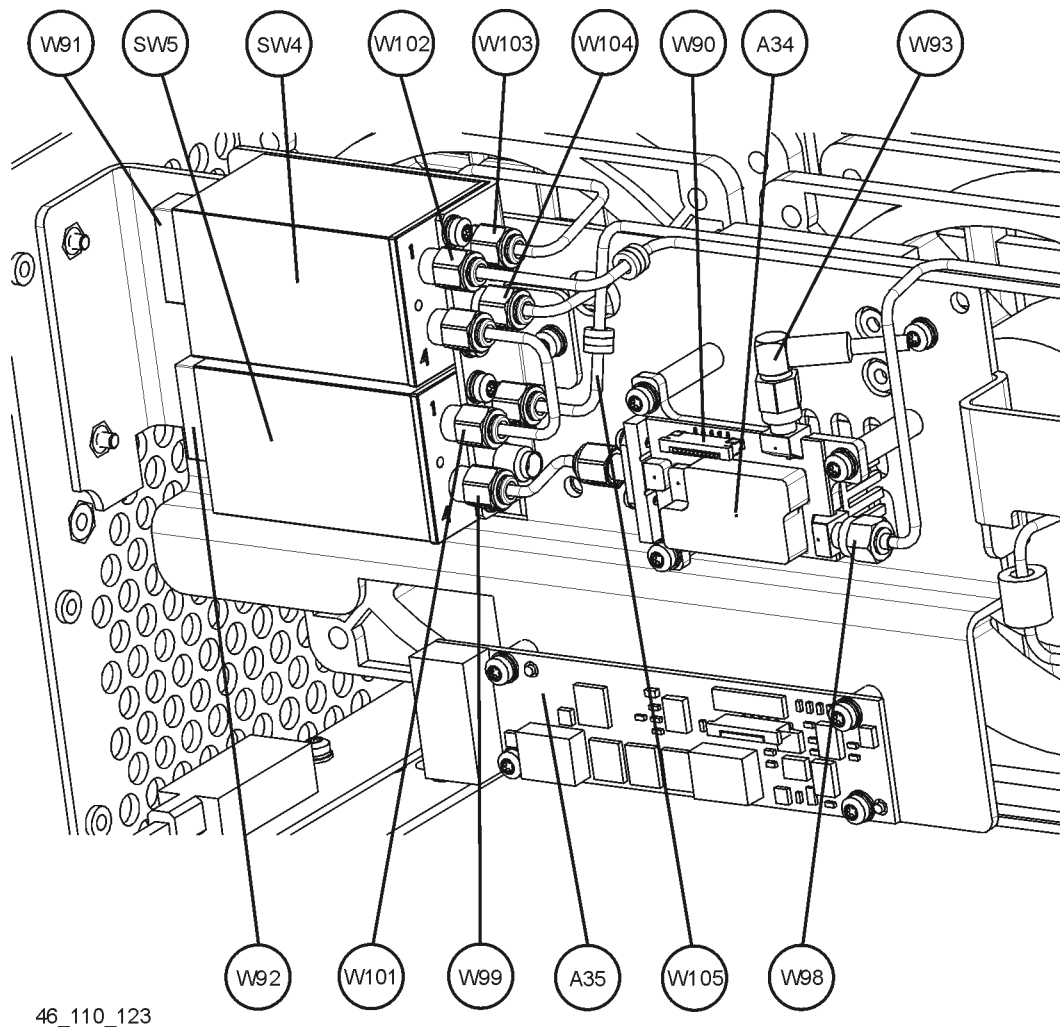

46\_110\_123

38. Connect Gray Flexible Cable W93 (Coaxial Switch Port 2 to Preselector Bypass Mixer). Torque to 10 in-lbs.

39. Reconnect cable W104 (Preamplifier Output to Switch SW4 Port 3). Torque to 10 in-lbs.

40. Reconnect cable W103 (A15 Attenuator to Switch SW4 Port 1). Torque to 10 in-lbs.

41. Reconnect cable W102 (Switch SW4 Port 3 to Preamplifier). Torque to 10 in-lbs.

42. Locate and install semi-rigid cable W101 from the kit. (Switch SW4 Port 4 to Switch SW4 Port 5). Torque to 10 in-lbs.
43. Locate Mixer Bias Board A35 (E4440-60254) and Thermal Pad (N1996-40018) from the kit. Refer to Figure 16. Use a pair of tweezers to carefully peel the clear protective cover from the pink side of the Thermal Pad. Apply the pink side of the Thermal Pad to the voltage regulator on the Mixer Bias Board as shown. (The voltage regulator is the square black component near the center of the board). Peel the blue protective cover off of the Thermal Pad.

**Figure 16** Mixer Bias Board

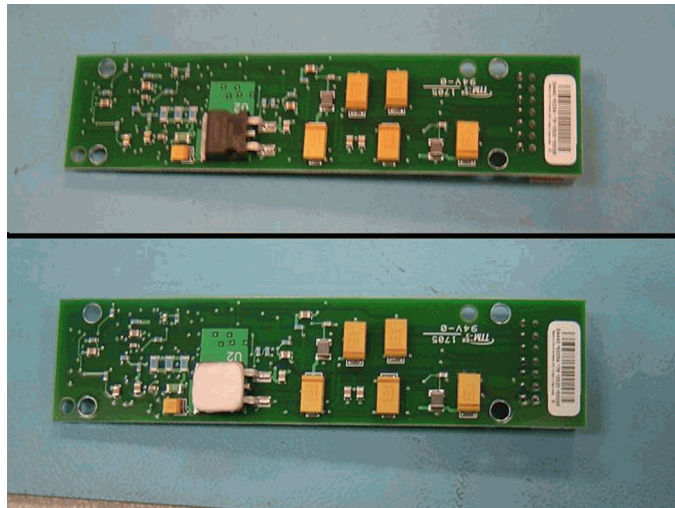

## Installation Procedure

44. Refer to Figure 17. Install Mixer Bias Board to the chassis by carefully aligning the board over the mounting holes and secure with four screws (0515-0372) as shown. Torque to 9 in-lbs. If you need to re-position the board to get the screws to line up make sure the Thermal Pad is still stuck to the Mixer Bias Board.

**Figure 17 Mixer Bias Board Installation**

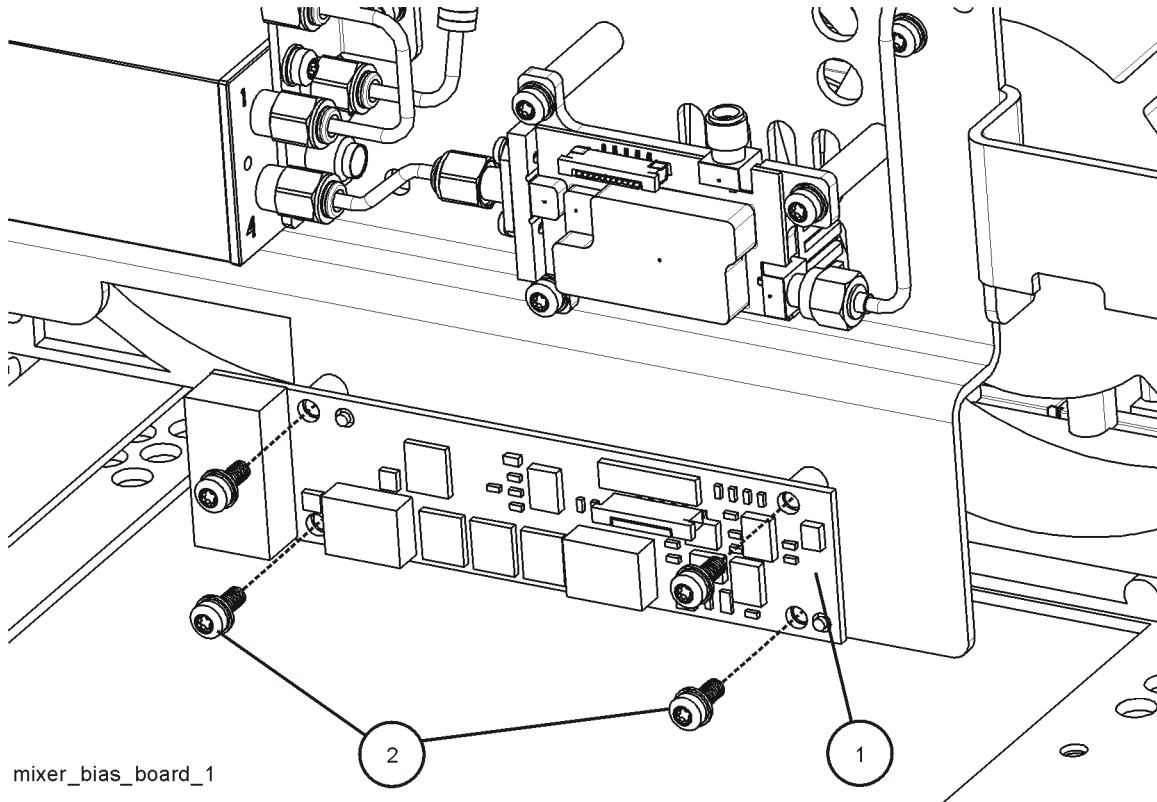



45. Refer to Figure 18. Locate and install Ribbon Cable 8150-5698 (2) from the kit (Mixer Bias Board to Unpreselected Mixer). Connect as shown.

**Figure 18 Mixer Bias Board Ribbon Cable**

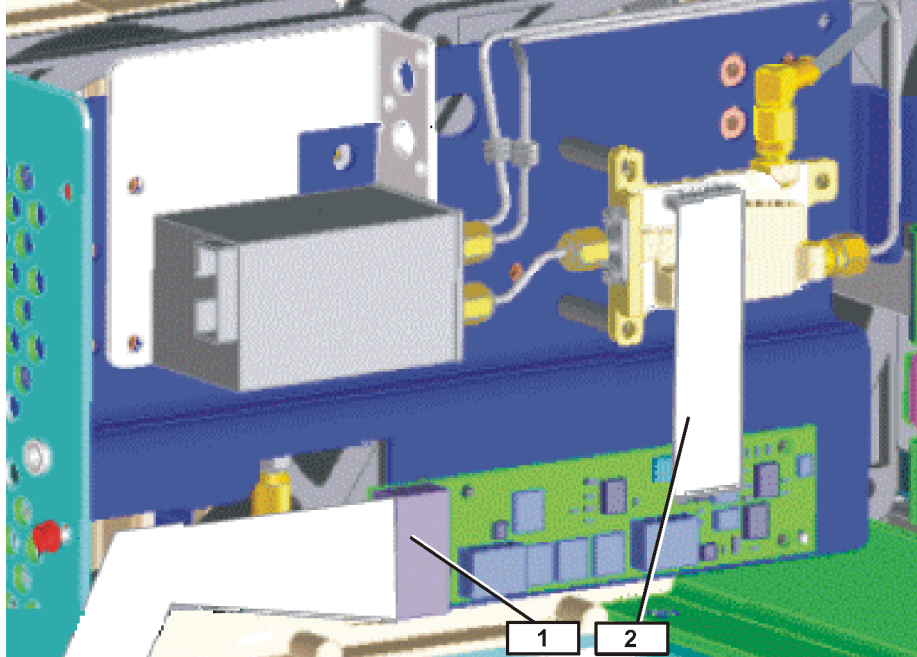

46. Locate and install Ribbon Cable E4440-60397 (1) from the kit. This cable's reference designator is W95. Connect one end of the Ribbon Cable to the Mixer Bias Board and the other end to the Option Driver assembly J7. Refer to Figure 33.

47. Refer to Figure 34 for cable routing.

## Installing Option 123 without Option 110

1. Refer to Figure 19. Locate the Mixer Bracket (E4440-00062) from the kit and install it.
  - a. Insert two screws (0515-0458) labeled as (2). Use T-15 driver to torque to 9 in-lbs
  - b. Insert two screws (0515-0372) labeled as (3). Use T-15 driver to torque to 9 in-lbs

**Figure 19** Bracket Installation

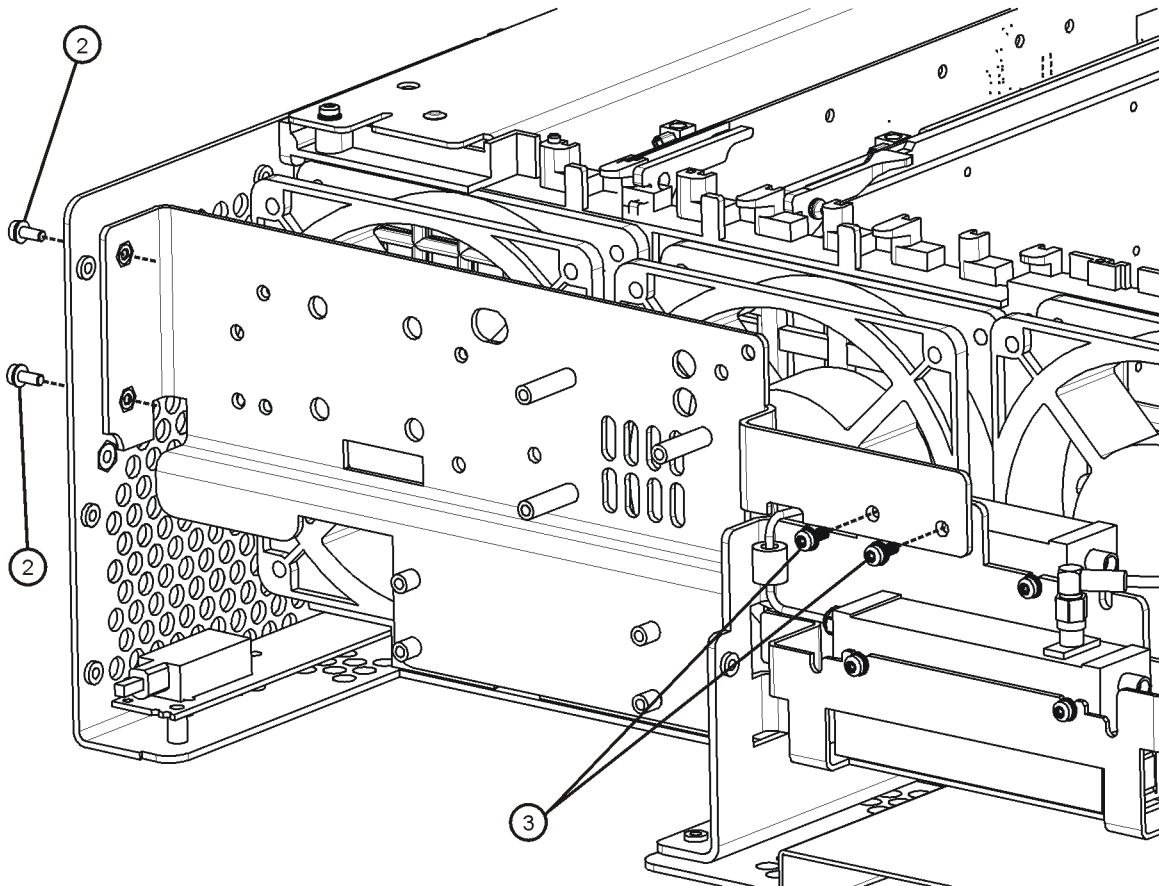

2. Locate the Coaxial Switch SW3 (N1810-60052) from the kit.
3. Locate the E4446-60373 gray flexible cable from the kit. This cable is reference designator W94. Connect cable W94 to Coaxial Switch SW3 Port C. Torque to 10 in-lbs.
4. Locate the E4446-60289 gray flexible cable from the kit. This cable is reference designator W93. Connect cable W93 to Coaxial Switch SW3 Port 2. Torque to 10 in-lbs.
5. Locate the E4446-60373 gray flexible cable from the kit. This cable is reference designator W89. Connect cable W89 to Coaxial Switch SW3 Port 1. Torque to 10 in-lbs.

6. Locate the Coaxial Switch Bracket (E4440-00076) from the kit. Refer to Figure 20. Install Coaxial Switch SW3 to Bracket with two screws (0515-0375). Torque to 9 in-lbs.

**Figure 20 SW3 and Bracket**

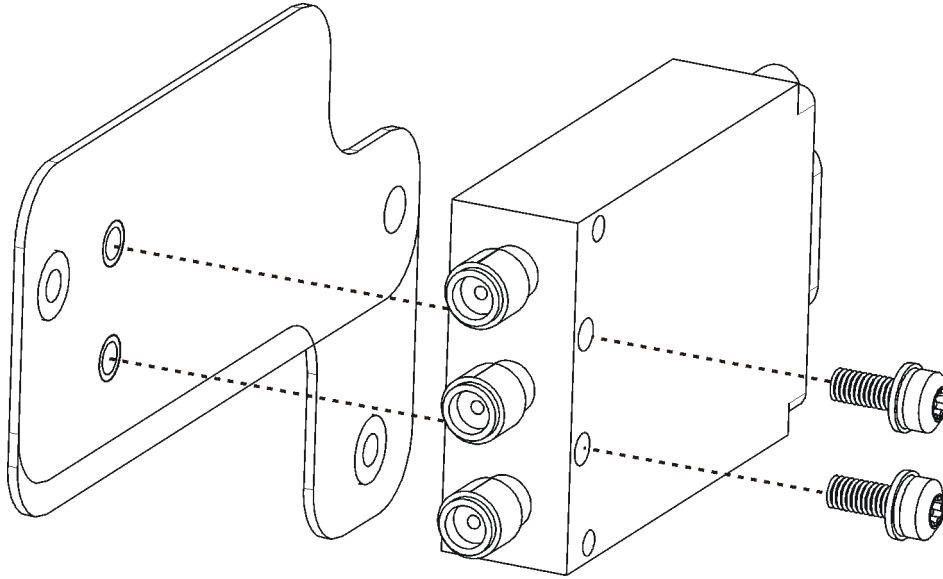

sw3\_bracket

7. Locate the E4446-60427 Ribbon Cable from the kit. This cable is reference designator W96. Connect cable W96 to Coaxial Switch SW3.

## Installation Procedure

8. Refer to Figure 21. Install Coaxial Switch Assembly (1) to the chassis with two screws (2) (0515-0430). Torque to 9 in-lbs.

**Figure 21 Coaxial Switch Assembly Installation**

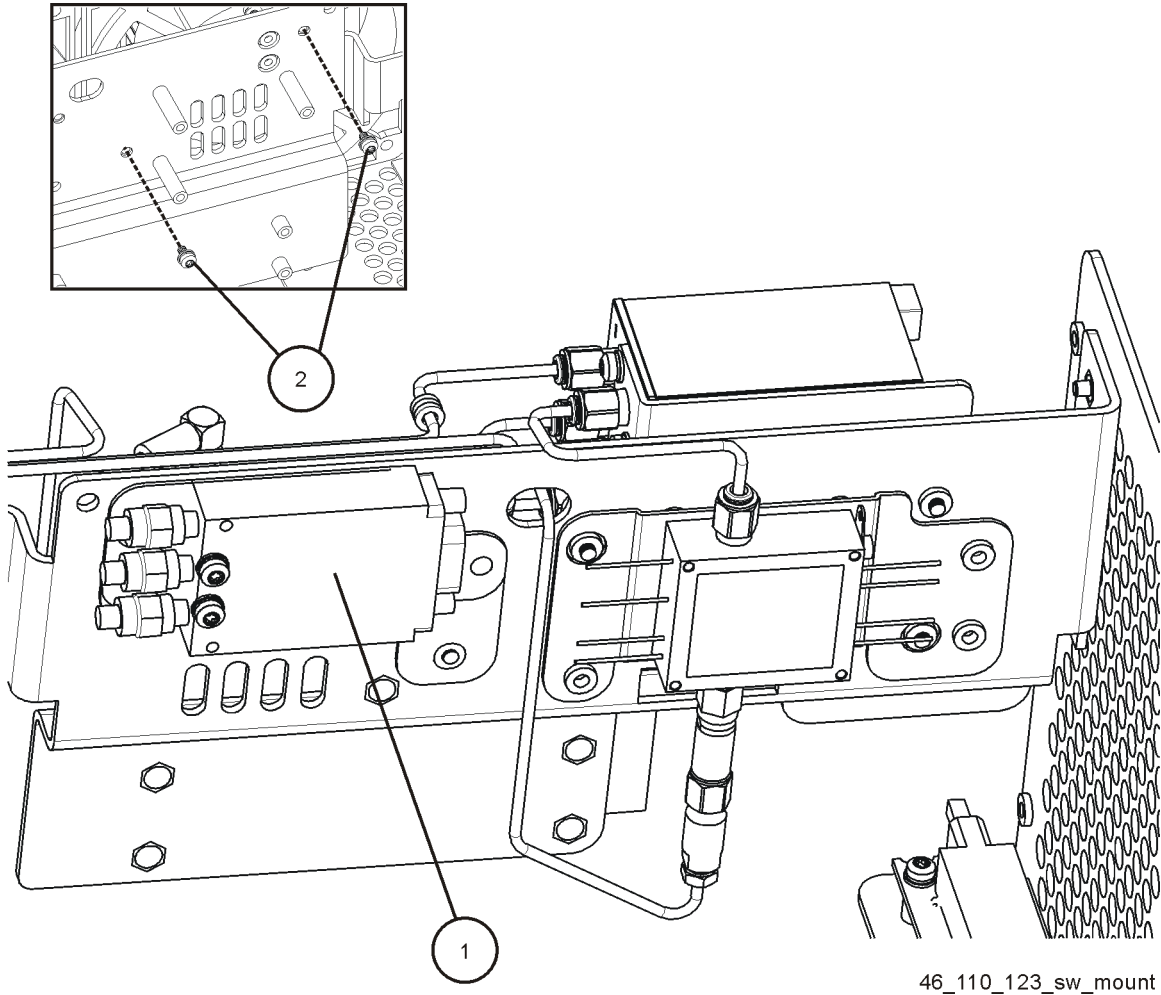

46\_110\_123\_sw\_mount

9. Locate Switch SW5 (87222-60015) and Switch Bracket (E4440-00063) from the kit. Refer to Figure 22. Install Switch SW5 to the bracket with three screws (0515-1934) as shown. Torque to 6 in-lbs with a Torx T-8 driver.

**Figure 22 SW5 and Bracket**

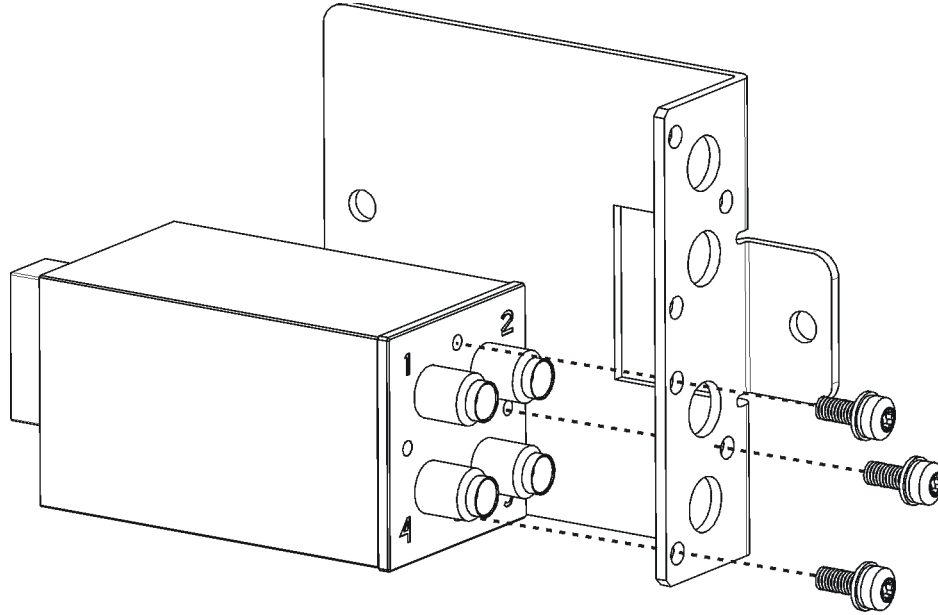

sw5\_bracket

## Installation Procedure

10. Refer to Figure 23. Install Switch SW5 Assembly to the Switch Bracket with three screws (1) (0515-0372) as shown. Leave screws loose to allow cables to be installed.

**Figure 23 SW5 Assembly Installation**

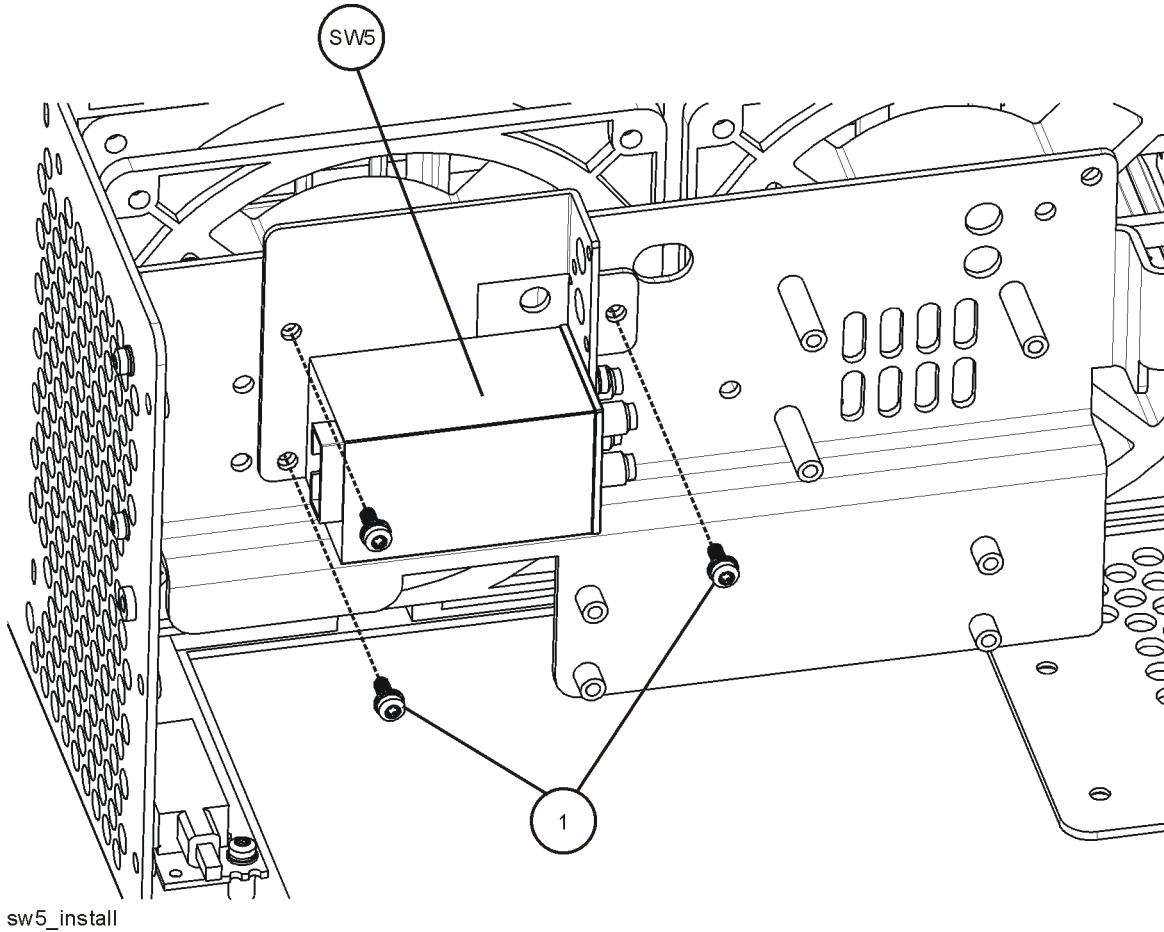

11. Locate Preselector Bypass Mixer (1NB7-8539) and E4440-20318 semi-rigid cable from the kit. This cable is reference designator W99. Refer to Figure 24. Connect W99 to the Preselector Bypass Mixer (1). Leave loose.
12. Connect cable W99 to Switch SW5 port 4 (2). Leave loose.

**Figure 24 W99 Installation**

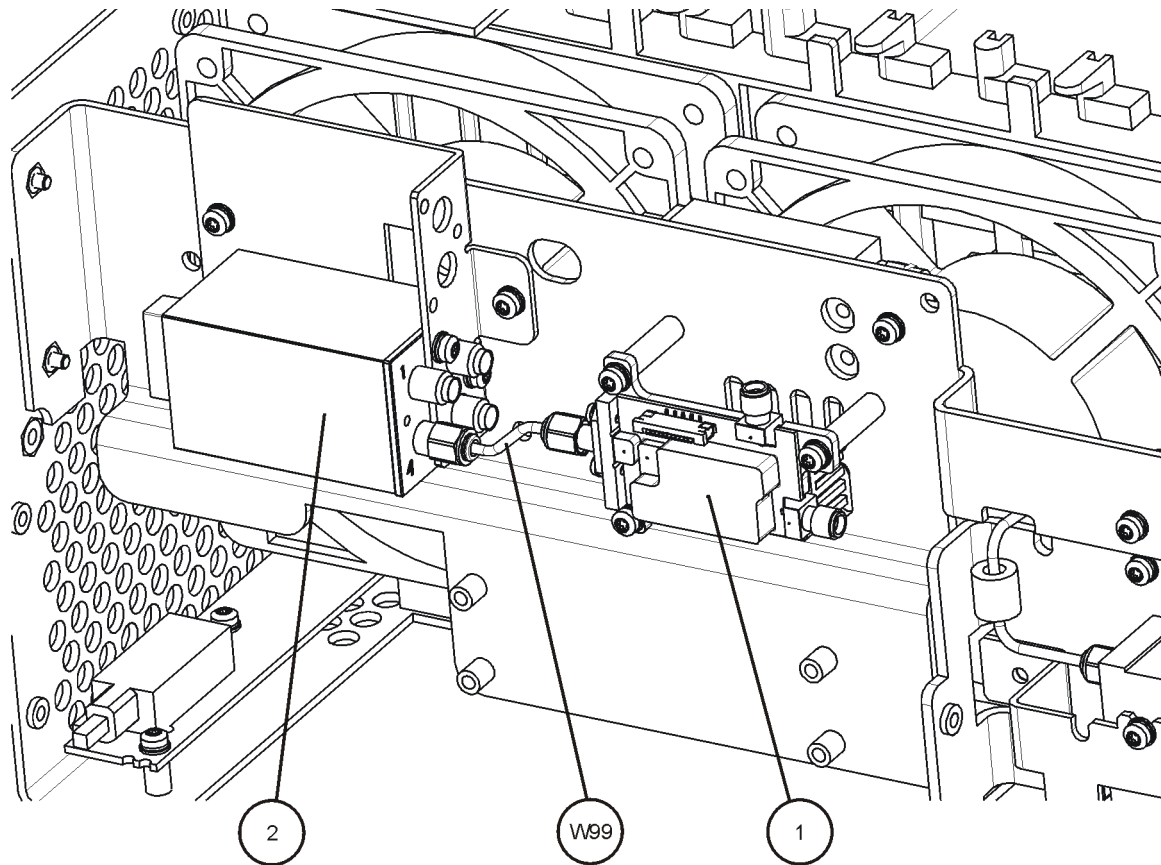

w99\_install

13. Install Preselector Bypass Mixer to Chassis with three screws (0515-0372) as shown. Torque to 9 in-lbs.
14. Go back and torque both ends of Cable W99 to 10 in-lbs.
15. Go back and torque the three screws on the Switch SW5 assembly to 9 in-lbs.
16. Locate E4440-60455, Ribbon Cable. This cable is reference designator W92. Connect Ribbon Cable to Switch SW5.

17. Refer to Figure 25. Remove the screw from the cable hold down rod on the mid web to allow the “10” cable and other cables to be free.

**Figure 25 Assembly and Cable Location**

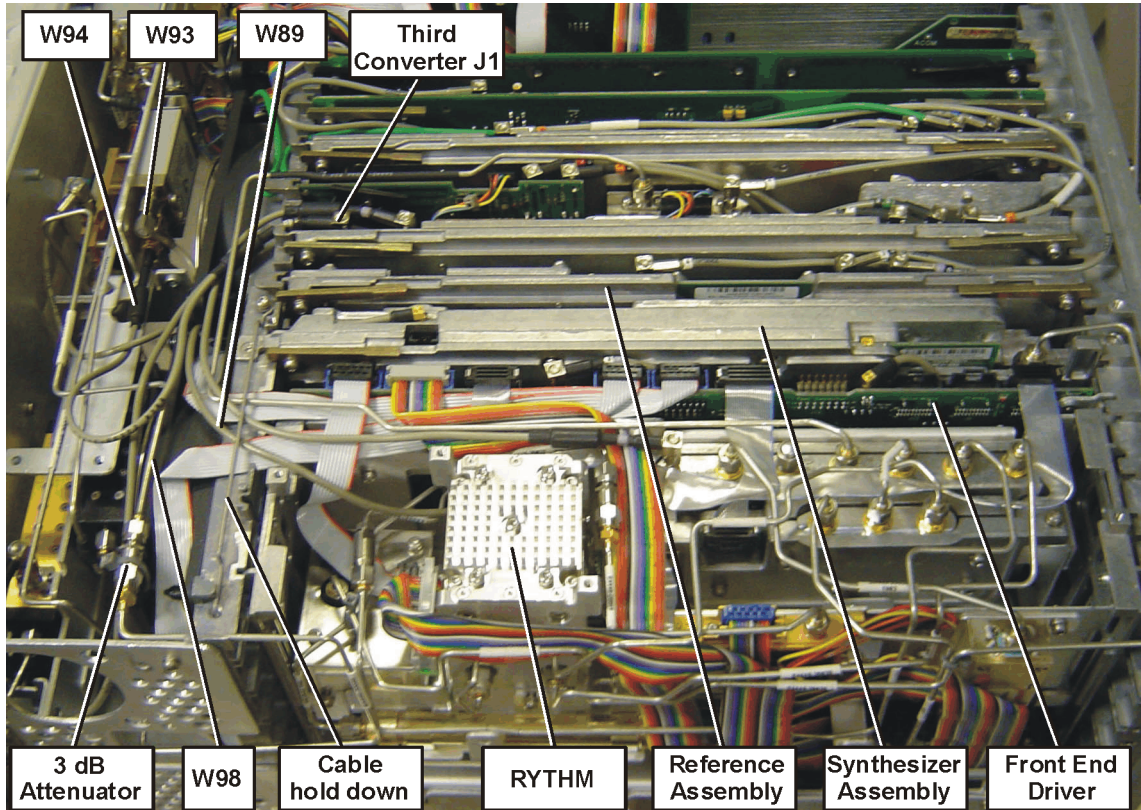

18. In order to remove the RYTHM end of the cable, and replace the cable, several board assemblies must be removed. Refer to Figure 25. Please note the position and routing of all cables. All of the flexible coax cables are color coded, but the ribbon cables are not.
19. Remove the Front End Driver being careful to avoid damaging the ribbon cables.
20. Remove the Synthesizer assembly after removing the rigid cable and the two retaining screws.
21. Remove the Reference assembly.



22. Locate cable W17 (RYTHM highband output to 3rd Converter J1) and take note of the cable routing. Refer to Figure 26. Using needle nose pliers, carefully grab the body of SMB connector and gently rock the SMB connector free of the RYTHM. Discard this cable.

**Figure 26**      **W17 Location**

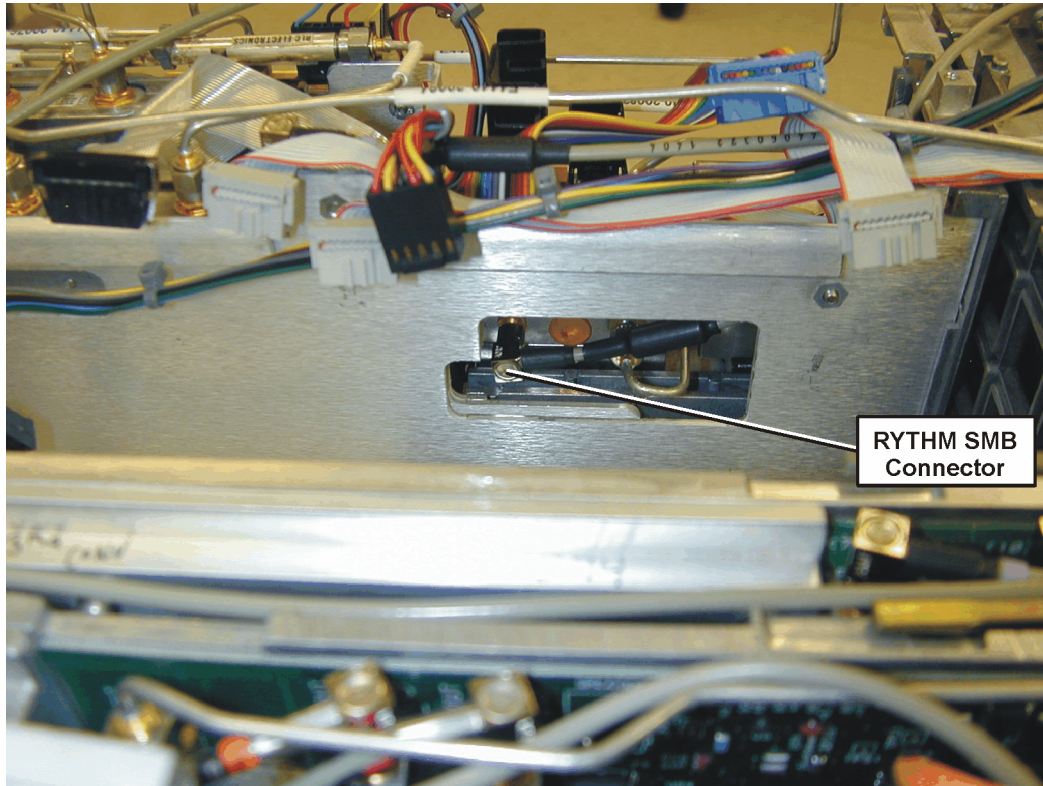

## Installation Procedure

23. Refer to Figure 27. Locate cable W89, one end is already connected to Switch SW3 bottom port. Route the cable next to the RF section sheet metal and directly to the RYTHM as shown. Carefully align the SMB connector end of the cable with the RYTHM connector by looking through the hole in the chassis. Press the SMB connector on.

**Figure 27 W89 Location**

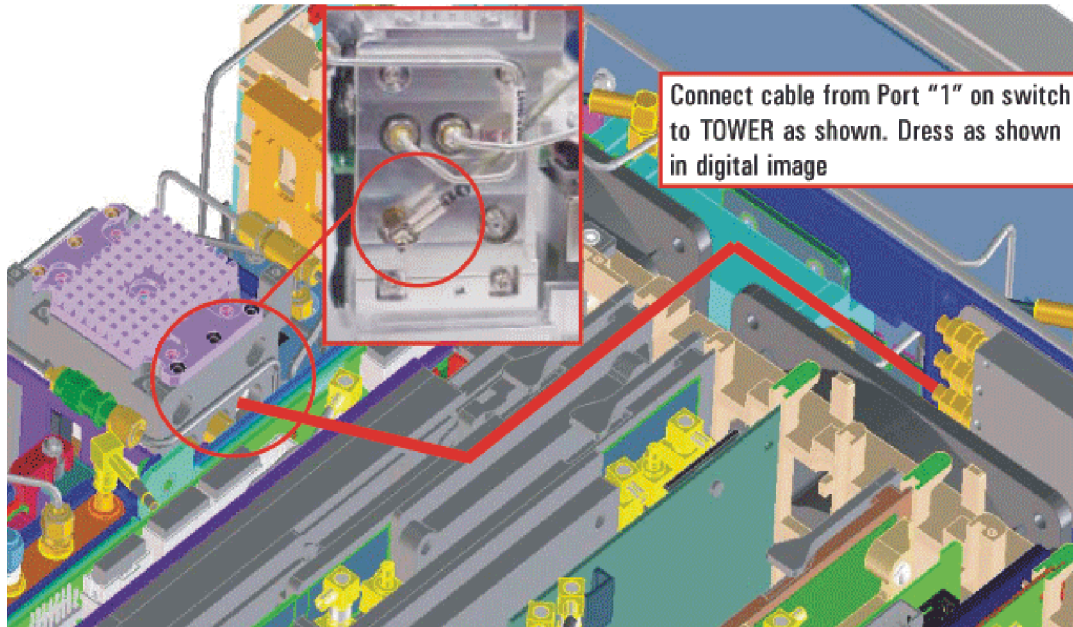

24. Reinstall the A13 Front End Driver, Synthesizer Assembly and the Reference Assembly. Assure all cables are routed correctly.

---

**NOTE** The shrink-wrapped ferrite beads on the cable can be moved slightly to aid cable routing.

---

25. Locate and remove cable W33 (Attenuator B to W34 on the RYTHM/SBTX). Discard this cable, since it will be replaced by another cable

26. Refer to Figure 28. Locate and install E4446-20080 semi-rigid cable from the kit. This cable is reference designator W105 (Switch SW5 Port 2 to W34 on the RYTHM/SBTX). Torque to 10 in-lbs.

**Figure 28 Option 123 Assemblies and Cables**

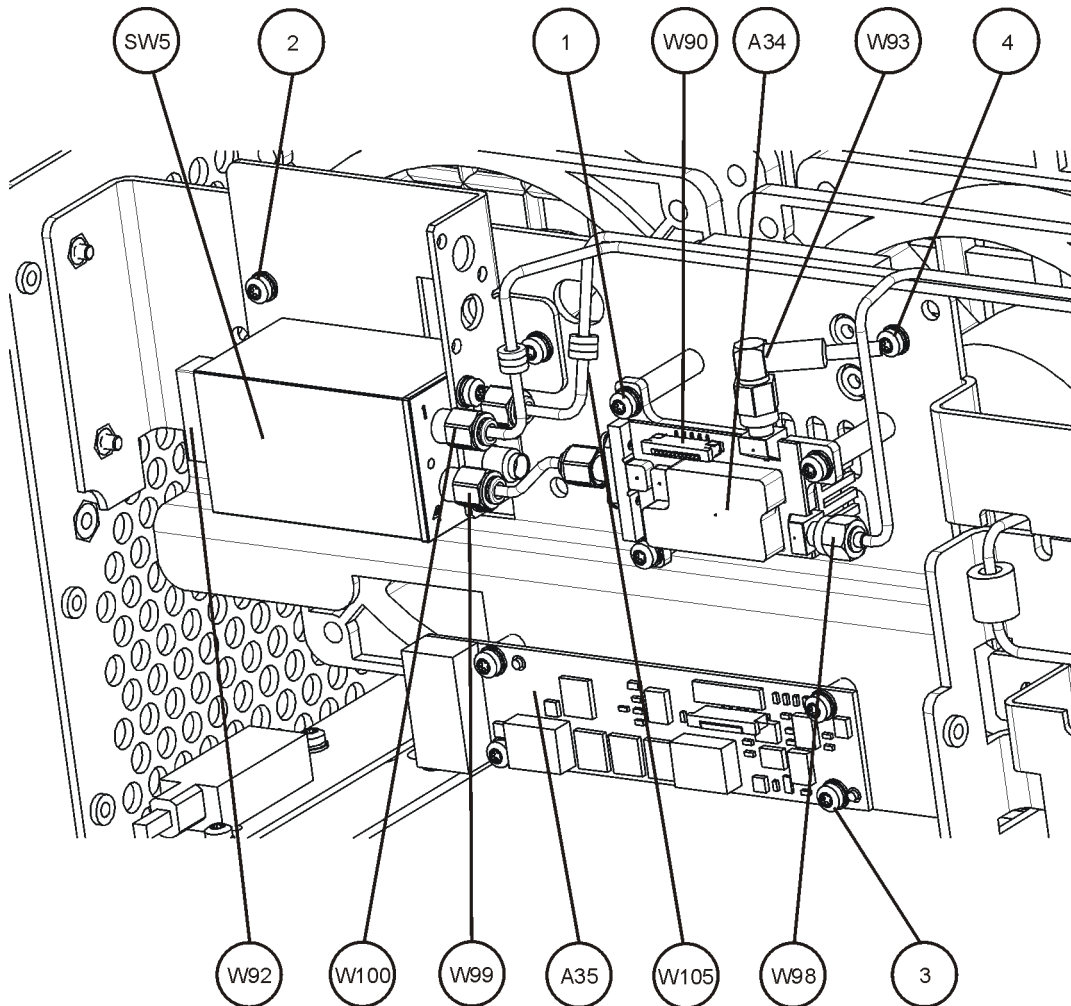

46\_123\_only

27. Locate and install E4446-20071 semi-rigid cable from the kit. This cable is reference designator W100 (Attenuator B to Switch SW5 Port 1). Torque to 10 in-lbs.

28. Locate and remove load from FELOMA J6 LO Out.\*

29. Locate E4446-20035 semi-rigid cable from the kit. This cable is reference designator W46. Connect cable W46 to A12 FELOMA J6 LO Out. Torque to 10 in-lbs.\*

\*Load will already be removed and Cable W46 will already be present if Option AYZ was previously installed.

---

**CAUTION** In the following step use a 7 mm wrench on the end of W46 to avoid stressing this cable. The cable can be damaged if it is allowed to rotate when loosening or tightening the Attenuator connector.

---

30. Locate 0955-0246 3 dB Attenuator from the kit. Connect 3 dB Attenuator to W46 as shown. Torque to 10 in-lbs.

---

**CAUTION** In the following step, use a 5/16 inch wrench on the wrench flat at the end of the attenuator to prevent the attenuator body from rotating when installing Cable W98. This attenuator and cable can be damaged if the attenuator is allowed to rotate when loosening or tightening the cable connector.

---

31. Locate E4446-20074 semi-rigid cable from the kit. (Preselector Bypass Mixer to 3 dB Attenuator / Cable W46 / A12 FELOMA) This cable is reference designator W98. Connect one end of W98 to the 3 dB Attenuator and the other end to the Preselector Bypass Mixer. Torque to 10 in-lbs.

32. Connect Cable W93 (Coaxial Switch Port 2 to Preselector Bypass Mixer) Torque to 10 in-lbs.

33. Locate Mixer Bias Board A35 (E4440-60254) and Thermal Pad (N1996-40018) from the kit. Use a pair of tweezers to carefully peel the clear protective cover from the pink side of the Thermal Pad. Refer to Figure 29. Apply the pink side of the Thermal Pad to the voltage regulator on the Mixer Bias Board. (The voltage regulator is the square black component near the center of the board). Peel the blue protective cover off of the Thermal Pad.

**Figure 29 Mixer Bias Board**

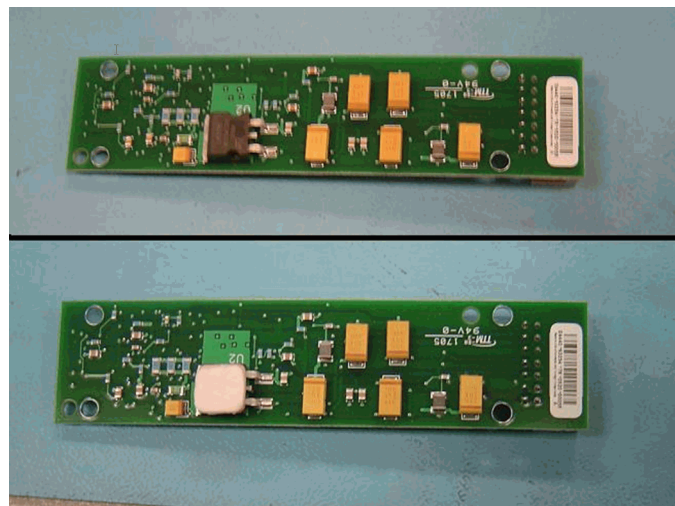

34. Refer to Figure 30. Install Mixer Bias Board (1) to the Chassis by carefully aligning the board over the mounting holes and secure with four screws (2) (0515-0372). Torque to 9 in-lbs. If you need to re-position the board to get the screws to line up make sure the Thermal Pad is still attached to the voltage regulator on the Mixer Bias Board.

**Figure 30 Mixer Bias Board Installation**

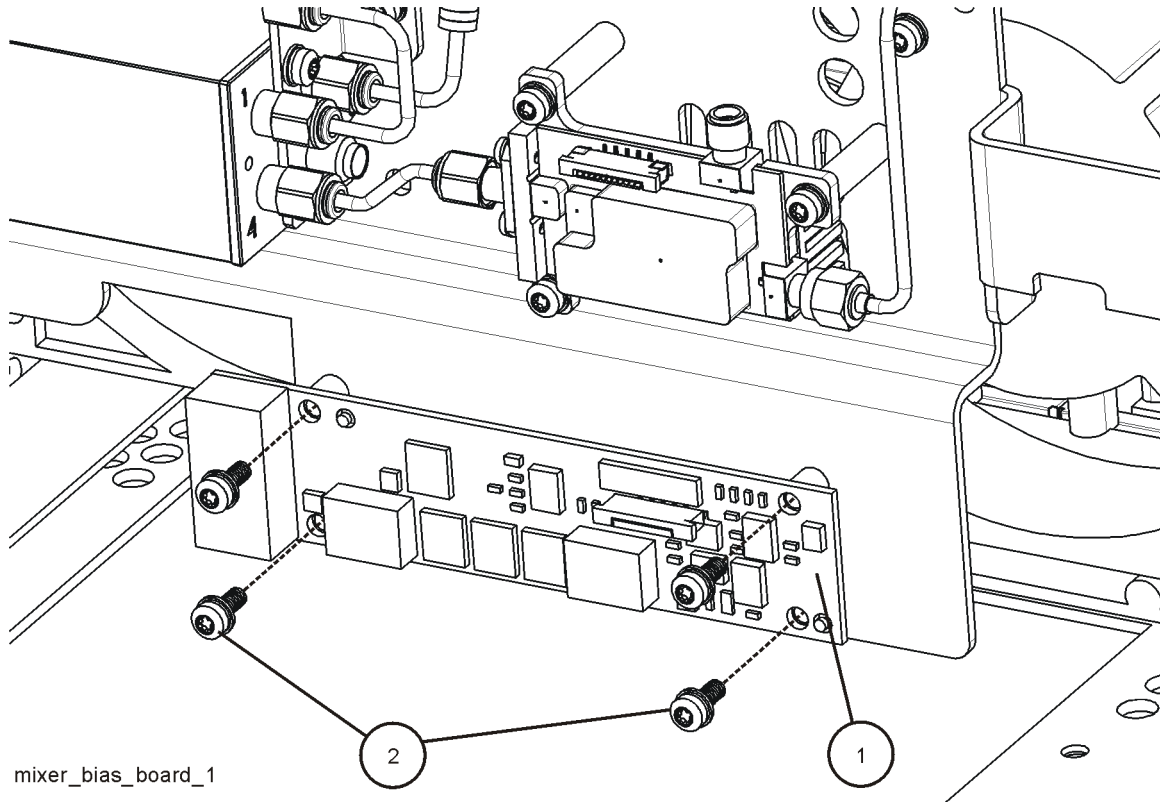

## Installation Procedure

35. Refer to Figure 31. Locate and install Ribbon Cable 8150-5698 from the kit. This cables reference designator is W90 (2). Connect between the Mixer Bias Board and the Unpreselected Mixer.

**Figure 31 Mixer Bias Board Ribbon Cable**

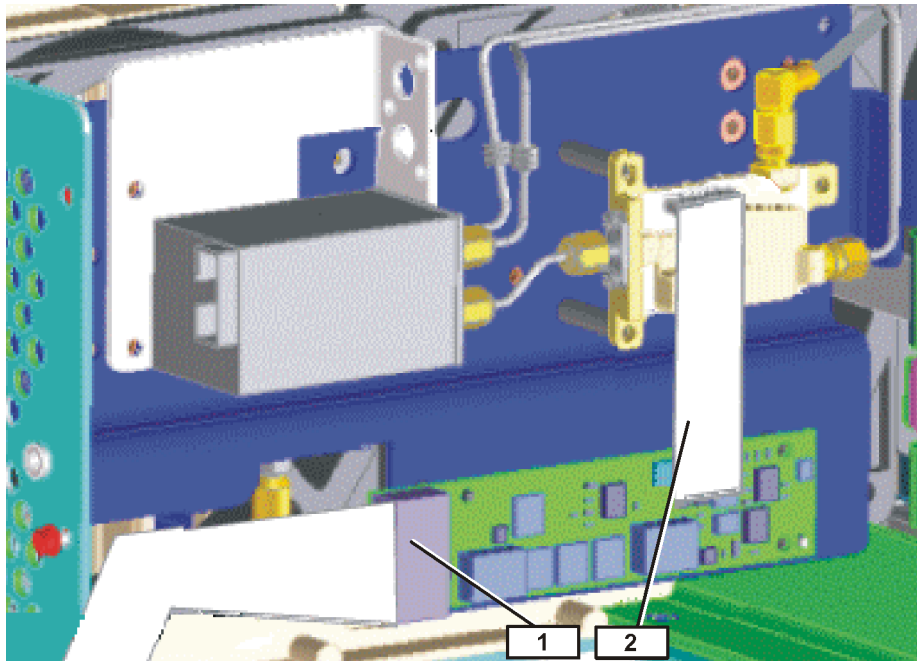

36. Locate and install Ribbon Cable E4440-60397 from the kit. This cables reference designator is W95. Connect the Ribbon Cable (1) to the Mixer Bias Board.

37. Connect Cable W94 (Coaxial Switch SW3 Port C to 3rd Converter Assembly J1).

## Installing the Option Driver Board

---

**NOTE** If Option 110 was not previously installed

---

1. Locate the Option Driver Board (E4440-60253) from the kit. Install the board into Option slot 0 as shown in Figure 32. Ensure the board is fully seated.

**Figure 32** Option Driver Board Installation

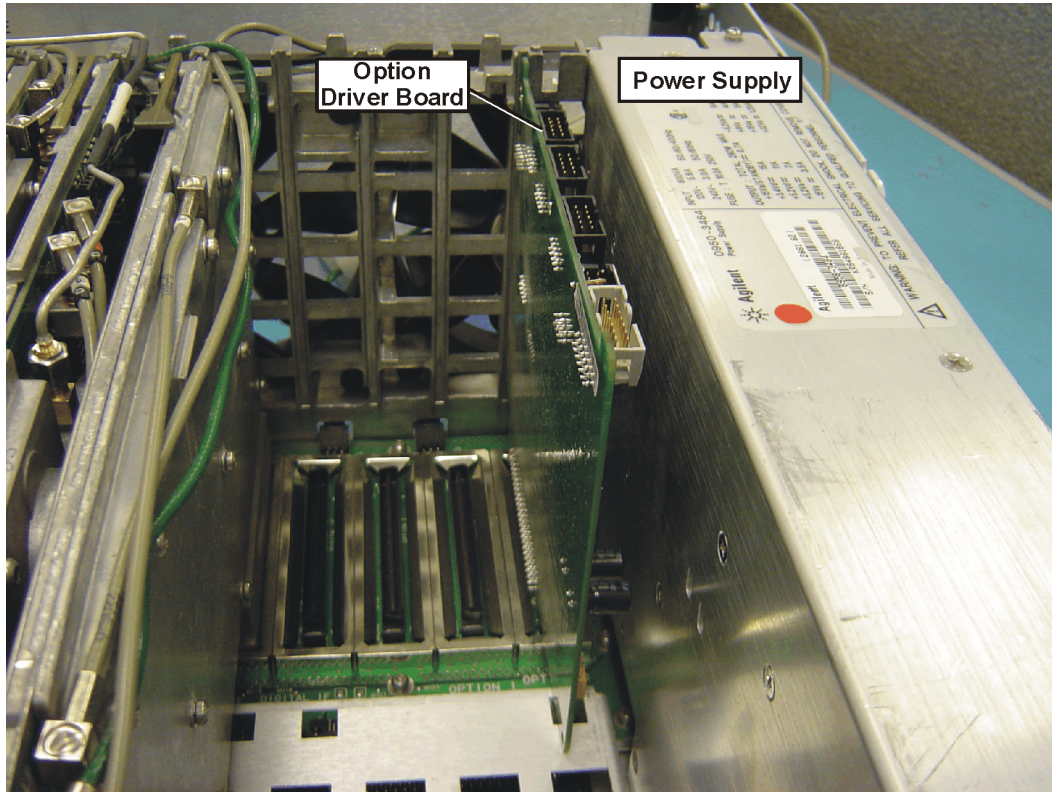

2. Connect Ribbon Cable W92 from Switch SW5 to Option Driver Board J8.

**Figure 33 Option Driver Board Cables**

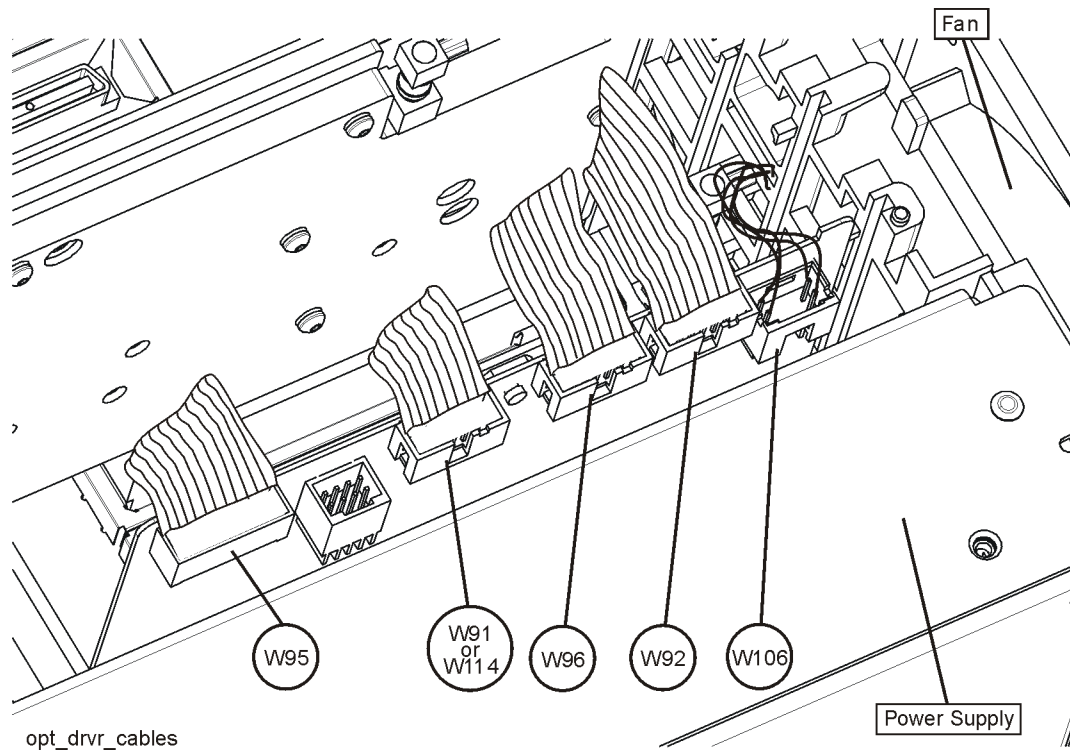

3. Connect Ribbon Cable W95 from the Mixer Bias Board to the Option Driver Assembly J7.
4. Connect Ribbon Cable W96 from the Coaxial Switch to the Option Driver Assembly J9.
5. If present, reconnect Wire Harness W106 from Preamplifier A36 to Option Driver Board P1. (Option 123 and Option 110 only)
6. If present, reconnect Ribbon Cable W91 from Switch SW4 to Option Driver Board J3. (Option 123 and Option 110 only)



- Refer to Figure 34. Locate 1400-0611, PVC Cable Clamp. Stick Cable Clamp to the top of the fan as shown and dress cables through the Cable Clamp as shown.

**Figure 34 Option Driver Board Cables**

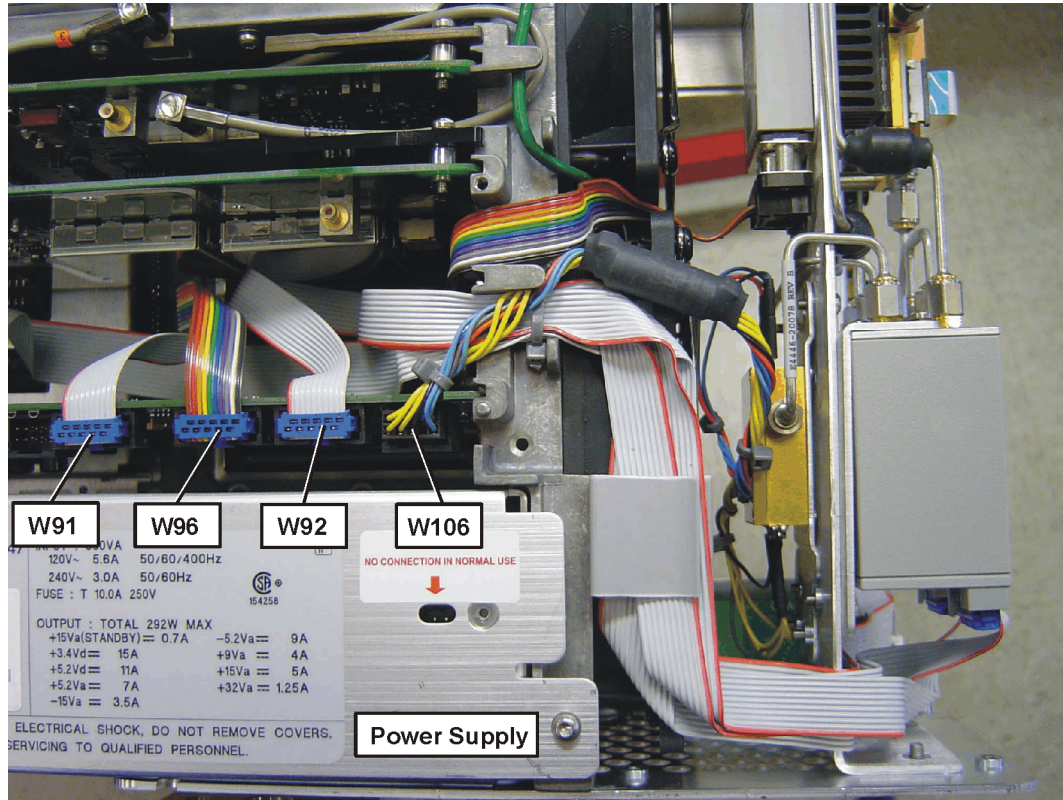

## Replace the Front Frame

- Place the front frame assembly in front of the deck.
- Connect the ribbon cable (3) to the A2 front panel interface board.
- Feed the coaxial cable BNC connector through the **External Trigger Input** hole in the front frame, matching the “D” slot. Secure with the nut removed earlier, using a 9/16” socket. Torque to 21 inch pounds.
- Clip the coaxial cable into the two cable clamps positioned on the front frame shield.
- Position the front frame on the deck using the alignment bosses on the deck (5). Remember to tuck the ribbon cable under the fans when pushing the frame onto the deck. This will insure proper airflow to cool the instrument. Using the T-10 driver, replace the 7 screws (1) that secure the front frame to the deck. Torque to 9 inch pounds.

## Replace the Top Brace and Outer Case

1. Refer to Figure 2 and Figure 1.
2. Replace the Top Brace as shown and slide the instrument cover back onto the deck from the rear. The seam on the cover should be on the bottom. Be sure the cover seats into the gasket groove in the front frame.
3. Replace the four rear feet onto the rear of the instrument. Torque to 236 Ncm (21 in-lb).
4. Use the T-20 driver to replace the handles. Torque to 236 Ncm (21 in-lb).
5. Replace the four bottom feet by pressing them into the holes in the case and sliding them in the opposite direction of the arrows until they click into place. Note that the feet at the front have the tilt stands.

## Installing the Option Designator and License Keyword

---

**NOTE** The option designator 123 and the license keyword must be entered into instrument memory in addition to the correct firmware before the hardware will function.

---

1. Locate the License Key Entitlement Certificate in the kit and follow the directions to redeem it. You will receive a License keyword Certificate that has the license keyword required for step 4.
2. Plug in instrument and power up. There may be alignment error messages since new hardware was installed.
3. On the instrument front panel press: **System, More**, until the **Licensing** softkey is visible. Press **Licensing** and **Option**. This will activate the alpha editor menu. Use the alpha editor and the front panel numerical keypad to enter the upper-case option designator 123. Enter the letters using the alpha editor and the numeric keypad to enter the numbers. Press the **Enter** key. Note that 123 now appears on the **Option** key.
4. Press **License Key**. The license keyword is a hexadecimal number that will require the entry of both letters and numbers. Use the alpha editor and the front panel numerical keypad to enter the license key number. Your entry will appear in the active function area of the display. If you make a typing error, use the backspace key to correct the error. Check the license key number you entered. Press **Enter, Activate License**.
5. Cycle instrument power and allow instrument to perform the auto align routine.

## **Install New Instrument Firmware**

Download the PSA Update Program and the PSA Firmware Procedure from [http://www.agilent.com/find/psa\\_firmware](http://www.agilent.com/find/psa_firmware) Follow the directions to install the firmware.

Alternate method:

Install the Firmware Upgrade Kit E4440AU Option UE2.

### **Verify the Option is enabled**

Check for the presence of option 123 by pressing **System, Show System** and looking for 123 in the Options section of the display.

Check for the recognition of new hardware by pressing **System, Show Hardware** and looking for the Option Driver Assembly.

## Utilities, Adjustments, and Performance Verification Tests Required

### Utilities Required

Under the Utilities test plan, perform the Calibration Constant Reset for Installing Option 123.

### Adjustments Required

<b>Adjustments</b>
Preselector Bypass Mixer Bias
Frequency Response adjustment above 3 GHz
Frequency Response adjustment (Option 123)
Frequency Response adjustment (Option 110) (if Option 110 is present)

### Performance Testing Required

The performance tests listed below are the minimum set that will verify the hardware retrofit just installed is functioning correctly. Performing only these tests does not guarantee the instrument meets all specifications.

**A full calibration is required to assure the instrument meets all specifications.**

<b>Performance Tests</b>
Residual Responses
Displayed Average Noise Level
Frequency Response above 3 GHz
Frequency Response (Option 123)
Frequency Response (Option 110) (if Option 110 is present)

Adjustments and performance testing requires the use of the calibration software. The latest software information and downloads are available at <http://www.agilent.com/find/calibrationsoftware>

End of installation

For assistance, get in touch with your nearest Agilent Technologies Sales and Service Office. To find your local Agilent office access the following URL, or call the following telephone number:

<http://www.agilent.com/find/assist>

1-800-452-4844 (8am-8pm EST)